



US010510265B2

(12) **United States Patent**  
**Jiao et al.**

(10) **Patent No.: US 10,510,265 B2**  
(45) **Date of Patent: \*Dec. 17, 2019**

- (54) **SYSTEM AND METHOD FOR DETERMINING AND USING KNOWLEDGE ABOUT HUMAN HEALTH** 5,711,297 A 1/1998 Iliff  
5,879,163 A 3/1999 Brown  
6,151,581 A \* 11/2000 Kraftson ..... G06Q 10/10  
705/3
- (71) Applicant: **Health Equity Labs**, Mountain View, CA (US) 7,319,970 B1 1/2008 Simone  
9,727,885 B1 8/2017 Reier  
2002/0035486 A1 3/2002 Huyn et al.
- (72) Inventors: **Shuo Jiao**, Sunnyvale, CA (US);  
**Munjaj Shah**, Los Altos, CA (US);  
**Ardaman Singh**, Union City, CA (US) 2003/0027122 A1 2/2003 Stansvik  
2003/0195772 A1\* 10/2003 Meek ..... G06Q 10/10  
705/2
- (73) Assignee: **Hi.Q, Inc.**, Mountain View, CA (US) 2005/0102171 A1 5/2005 Ashley  
2005/0182659 A1 8/2005 Huttin  
2005/0228692 A1 10/2005 Hodgdon  
2005/0234742 A1 10/2005 Hodgdon  
2007/0061166 A1 3/2007 Ramasubramanian  
2007/0118398 A1 5/2007 Perls  
2007/0129611 A1\* 6/2007 Ratka ..... G06F 19/3456  
600/300
- (\* ) Notice: Subject to any disclaimer, the term of this patent is extended or adjusted under 35 U.S.C. 154(b) by 242 days.  
This patent is subject to a terminal disclaimer.

(Continued)

(21) Appl. No.: **14/542,498**

(22) Filed: **Nov. 14, 2014**

(65) **Prior Publication Data**

US 2016/0140859 A1 May 19, 2016

(51) **Int. Cl.**  
**G09B 7/06** (2006.01)  
**G16H 50/30** (2018.01)

(52) **U.S. Cl.**  
CPC ..... **G09B 7/06** (2013.01); **G16H 50/30** (2018.01)

(58) **Field of Classification Search**  
CPC ... G09B 7/00; G09B 7/02; G09B 7/04; G09B 7/06; G06Q 30/0203; G06Q 50/00  
See application file for complete search history.

(56) **References Cited**

U.S. PATENT DOCUMENTS

- 5,572,421 A 11/1996 Altman et al.
- 5,639,471 A \* 6/1997 Chait ..... A61B 5/00  
424/400

**FOREIGN PATENT DOCUMENTS**

WO WO-2011/058463 A2 5/2011

**OTHER PUBLICATIONS**

International Search Report and Written Opinion from PCT Application No. PCT/US2015/060723, dated Feb. 4, 2016, 9 pages.

(Continued)

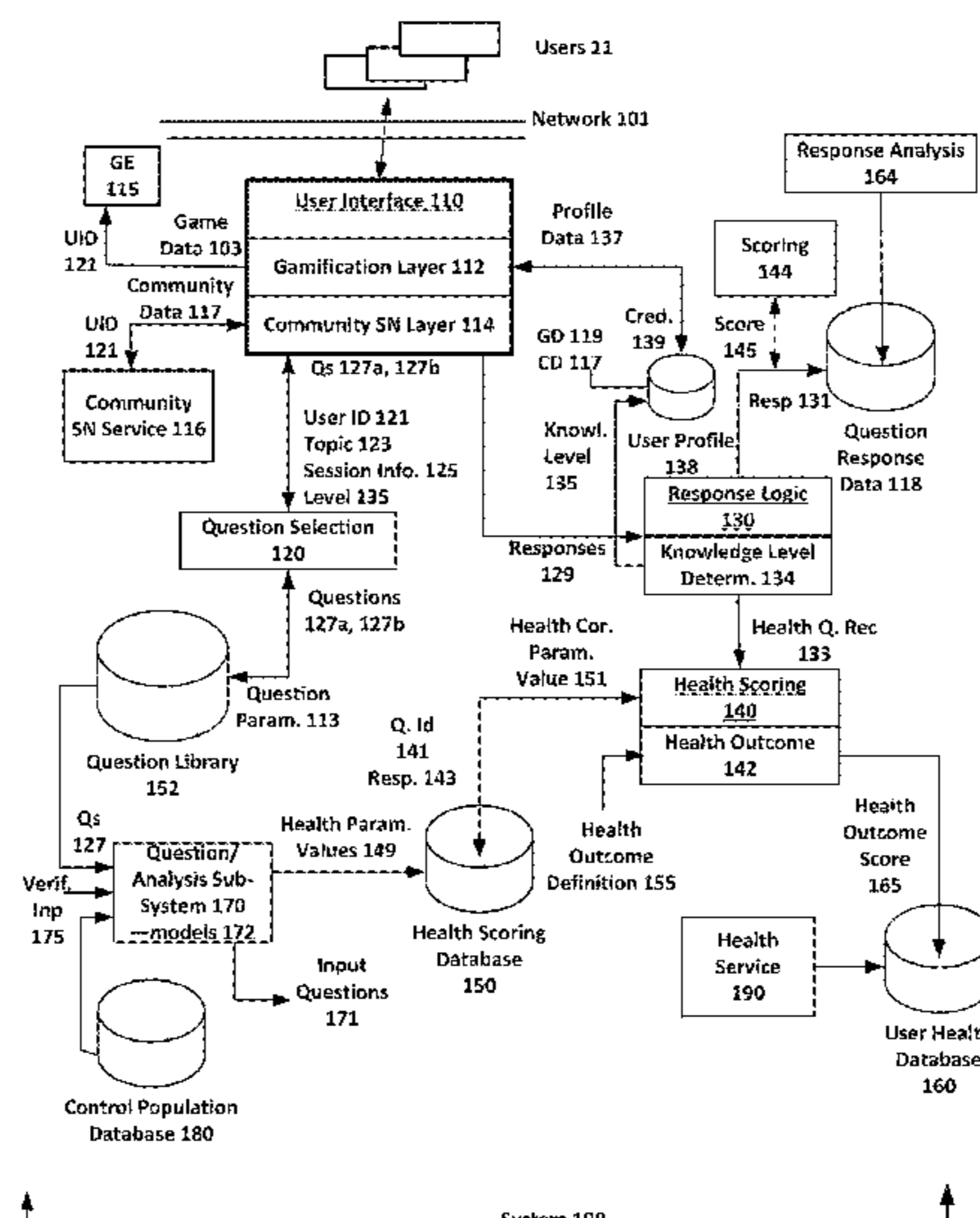
*Primary Examiner* — Robert J Utama

(74) *Attorney, Agent, or Firm* — Mahamedi IP Law LLP

(57) **ABSTRACT**

A system and method for predicting a health outcome of a user based on a determination of knowledge the user possesses regarding issues of physiological or mental health.

**20 Claims, 10 Drawing Sheets**



(56)

References Cited

U.S. PATENT DOCUMENTS

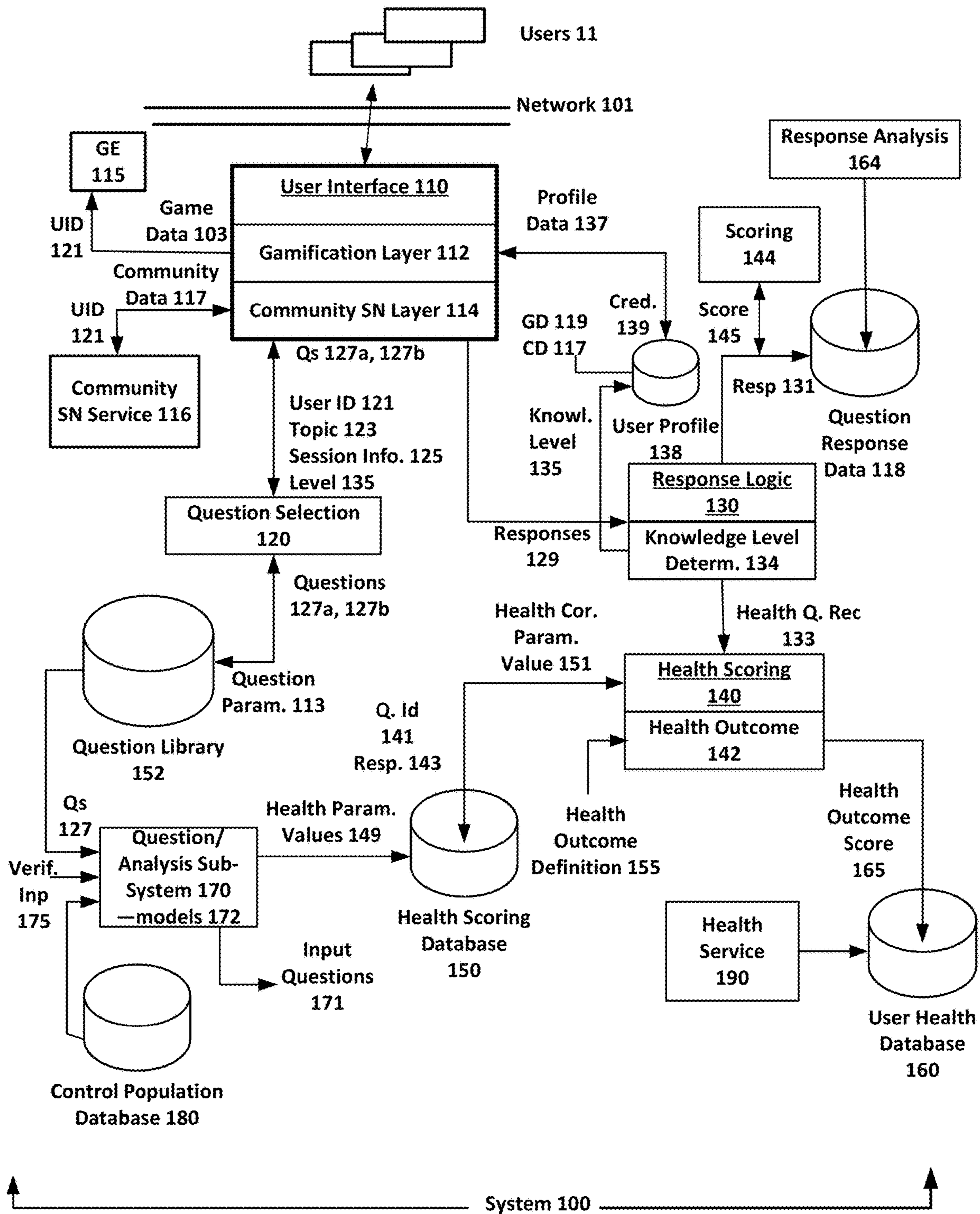
2009/0055915 A1\* 2/2009 Piliouras ..... G06F 21/41  
726/8  
2009/0241028 A1\* 9/2009 Iskedjian ..... G06Q 10/10  
715/727  
2011/0022420 A1 1/2011 Morse  
2011/0307311 A1 12/2011 Turgiss  
2012/0004925 A1\* 1/2012 Braverman ..... G06F 19/325  
705/2  
2012/0041788 A1 2/2012 Wons  
2012/0123802 A1 5/2012 Feldman  
2012/0156664 A1\* 6/2012 Hurwitz ..... G09B 23/28  
434/262  
2012/0251993 A1\* 10/2012 Chidambaran ..... G09B 7/00  
434/362  
2013/0024212 A1 1/2013 Atakhorrani  
2013/0035207 A1 2/2013 Abuelsaad  
2013/0096942 A1\* 4/2013 Bowles ..... G06Q 50/22  
705/2  
2013/0117040 A1 5/2013 James et al.  
2013/0138450 A1 5/2013 Vigneux  
2013/0211858 A1 8/2013 Ohnemus  
2013/0230841 A1\* 9/2013 Bremer ..... G06Q 30/0203  
434/322  
2013/0291098 A1 10/2013 Chung  
2013/0332189 A1\* 12/2013 Manning ..... G06F 19/363  
705/2  
2014/0087355 A1 3/2014 Henry  
2014/0156308 A1 6/2014 Ohnemus  
2014/0214441 A1 7/2014 Young  
2014/0257852 A1 9/2014 Walker  
2014/0278474 A1 9/2014 McClure

2014/0316811 A1 10/2014 Ohnemus  
2015/0046174 A1 2/2015 Mainwaring  
2015/0104759 A1 4/2015 Block  
2015/0161538 A1 6/2015 Matus  
2015/0161738 A1 6/2015 Stempora  
2015/0317650 A1 11/2015 Mahoney  
2016/0049084 A1 2/2016 Chamberlain  
2016/0086505 A1 3/2016 Hanlon  
2016/0188813 A1\* 6/2016 Hennenfent ..... G06F 19/327  
705/2  
2016/0203284 A1 7/2016 Ouyang  
2016/0246947 A1 8/2016 Yao  
2016/0335404 A1 11/2016 Srinivas  
2017/0132396 A1 5/2017 Bechtold  
2017/0193165 A1\* 7/2017 Mandalika ..... G16H 50/30

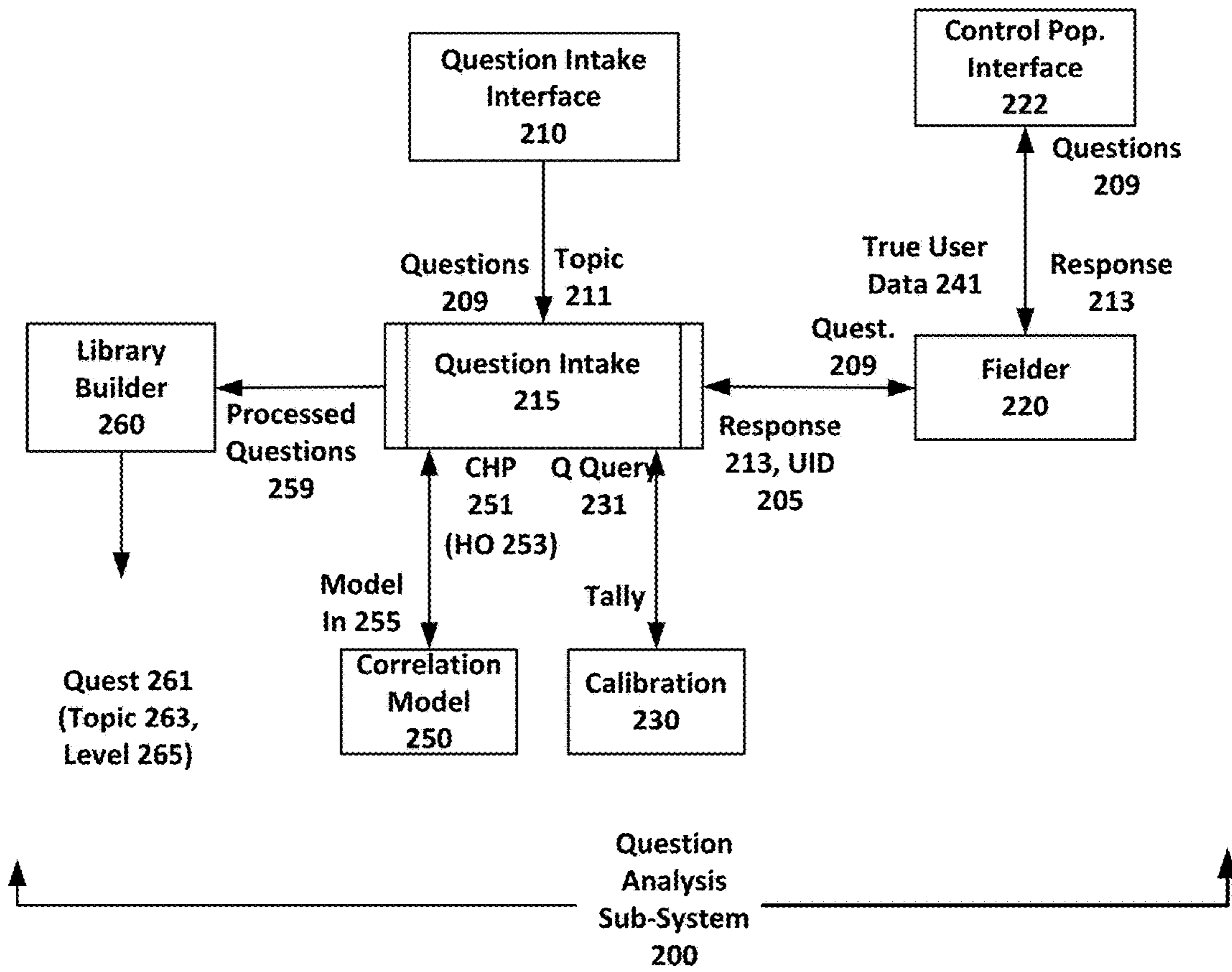
OTHER PUBLICATIONS

Notification Concerning Transmittal of International Preliminary Report on Patentability PCT Application No. PCT/US2015/060723, dated May 26, 2017, 8 pages.  
International Search Report and Written Opinion from PCT Application No. PCT/US2017/052804, dated Dec. 7, 2017, 7 pages.  
Prokoshfina N.R. Prognozirovanie odnositel'nogo riska obschey smertnosti u lits s arterial'noy gipertenziey (po dannym desyatiletnego kogortnogo issledovaniya). Vestnik Vitebskogo gosudarstvennogo meditsinskogo universiteta, 2011, pp. 54-62.  
Batura T.V. Programmnye produkty i sistemy. Nauchno-Prakticheskoe izdanie. Tver 2013, X2 3 (103), pp. 130-137.  
European Search Report dated Jul. 23, 2018, Application No. 15859764.1 8 pages.

\* cited by examiner



**FIG. 1**



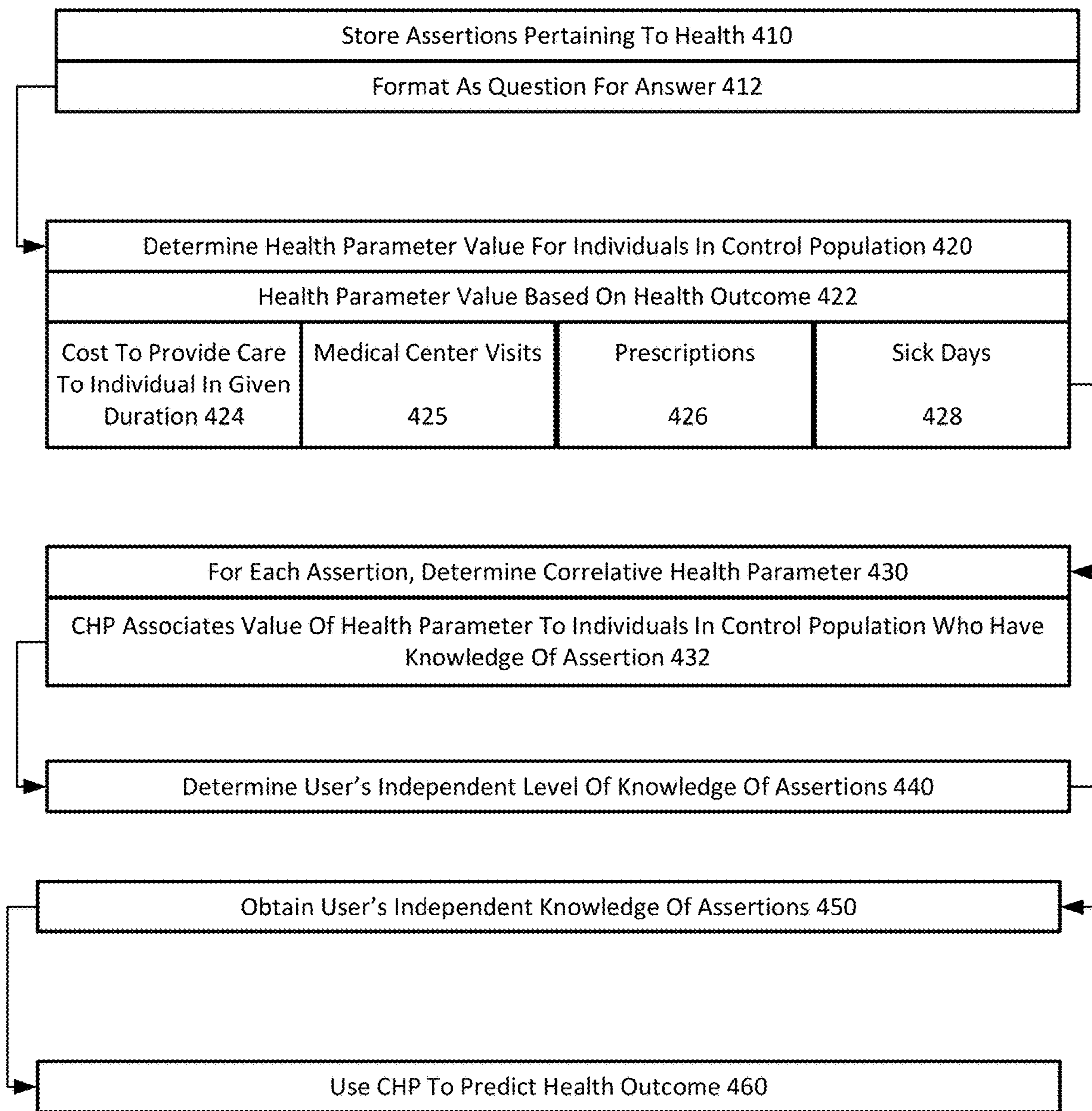
**FIG. 2**

300

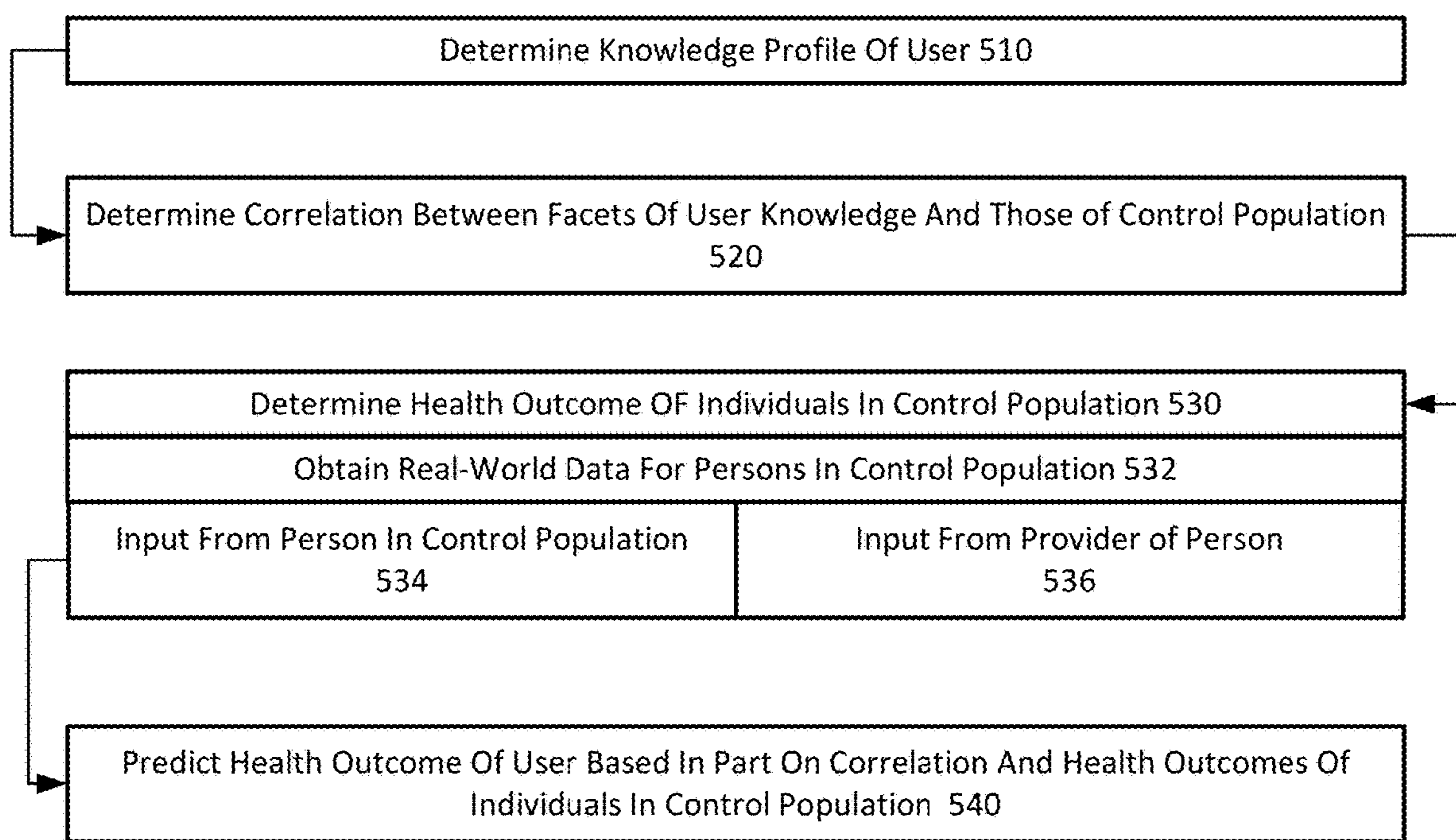
QID	HO1	HO2	HO3	HO4	Topic1	Topic2	Topicn
0001	CF1	0	0	0	TCF1	TCF2	0
0002	0	CF2	0	0	0	TCF4	
0003	0	0	0	CF4	0	0	TCF5
0004	0	0	CF3	0	0	0	
0005	0	0	0	0	0	0	
0006	0	0	0	0	0	0	

301, 303, 305

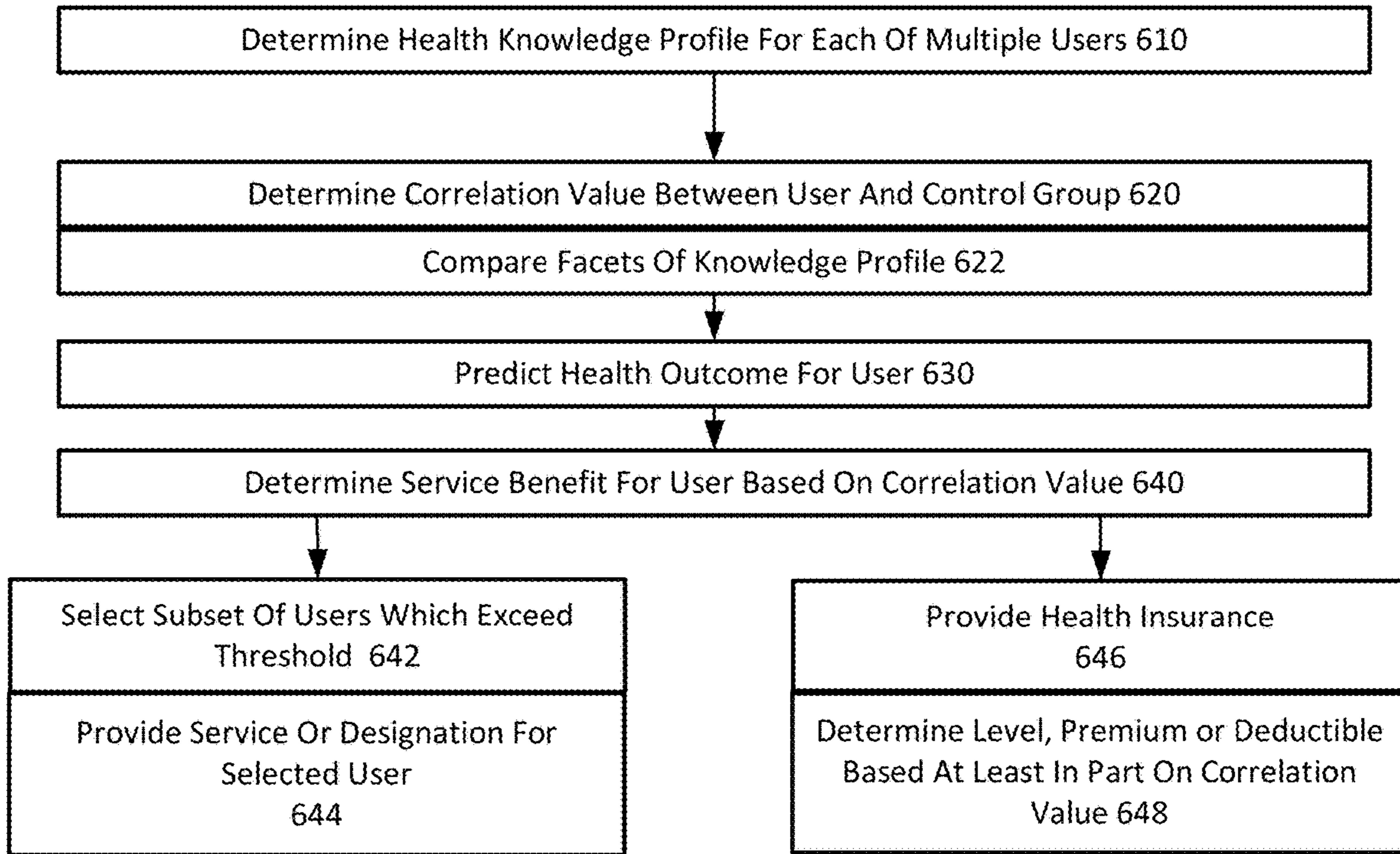
**FIG. 3**



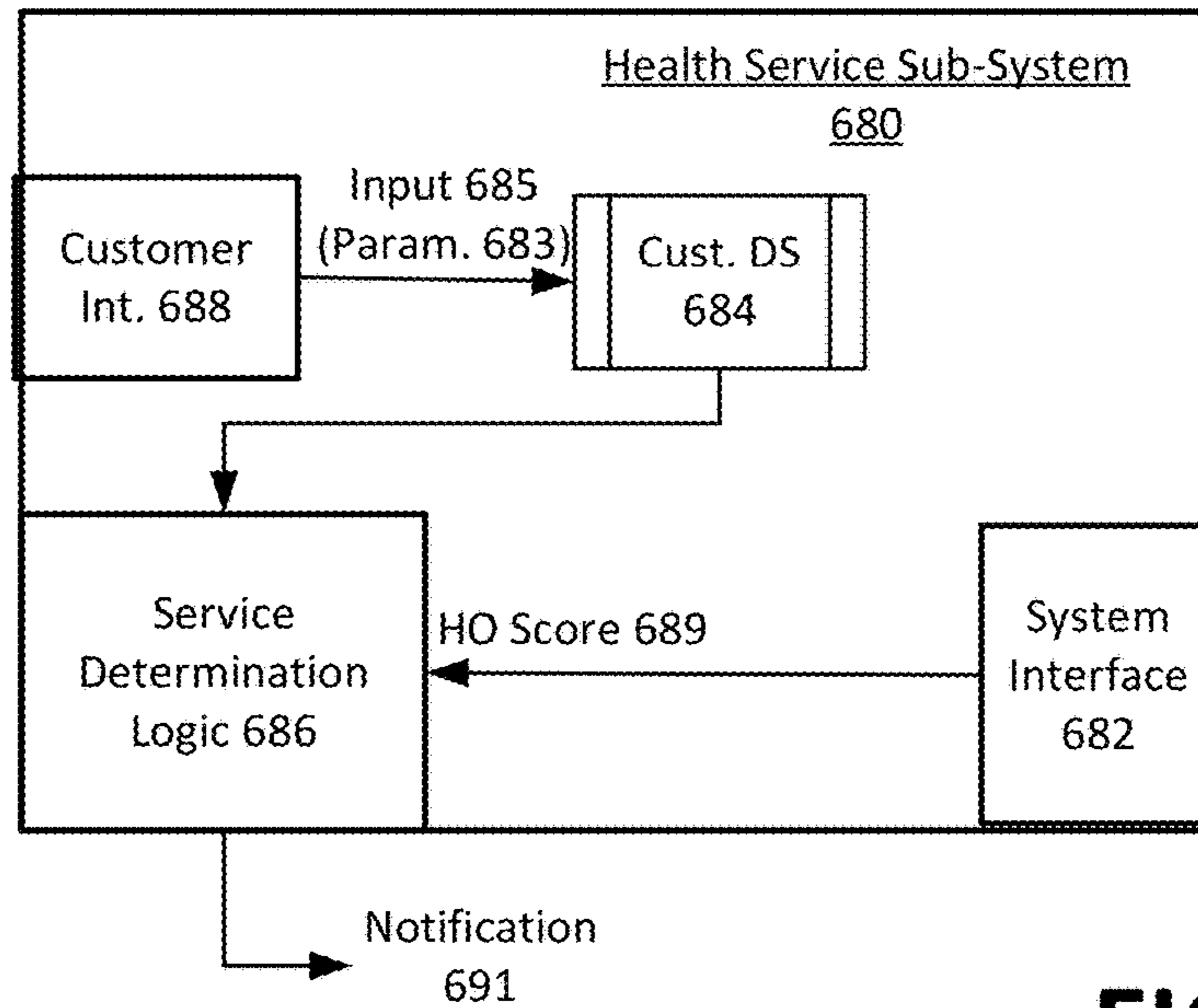
**FIG. 4**



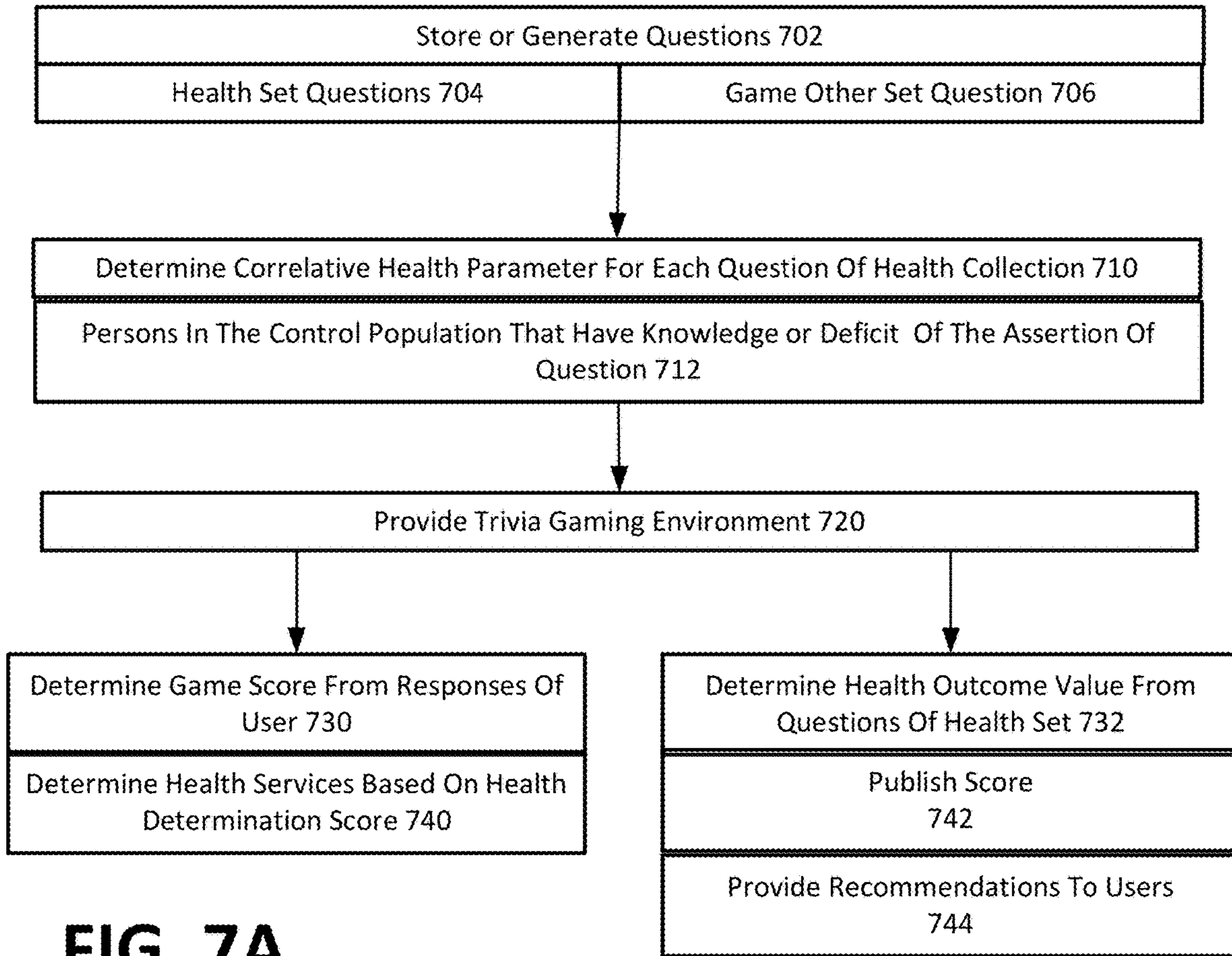
**FIG. 5**



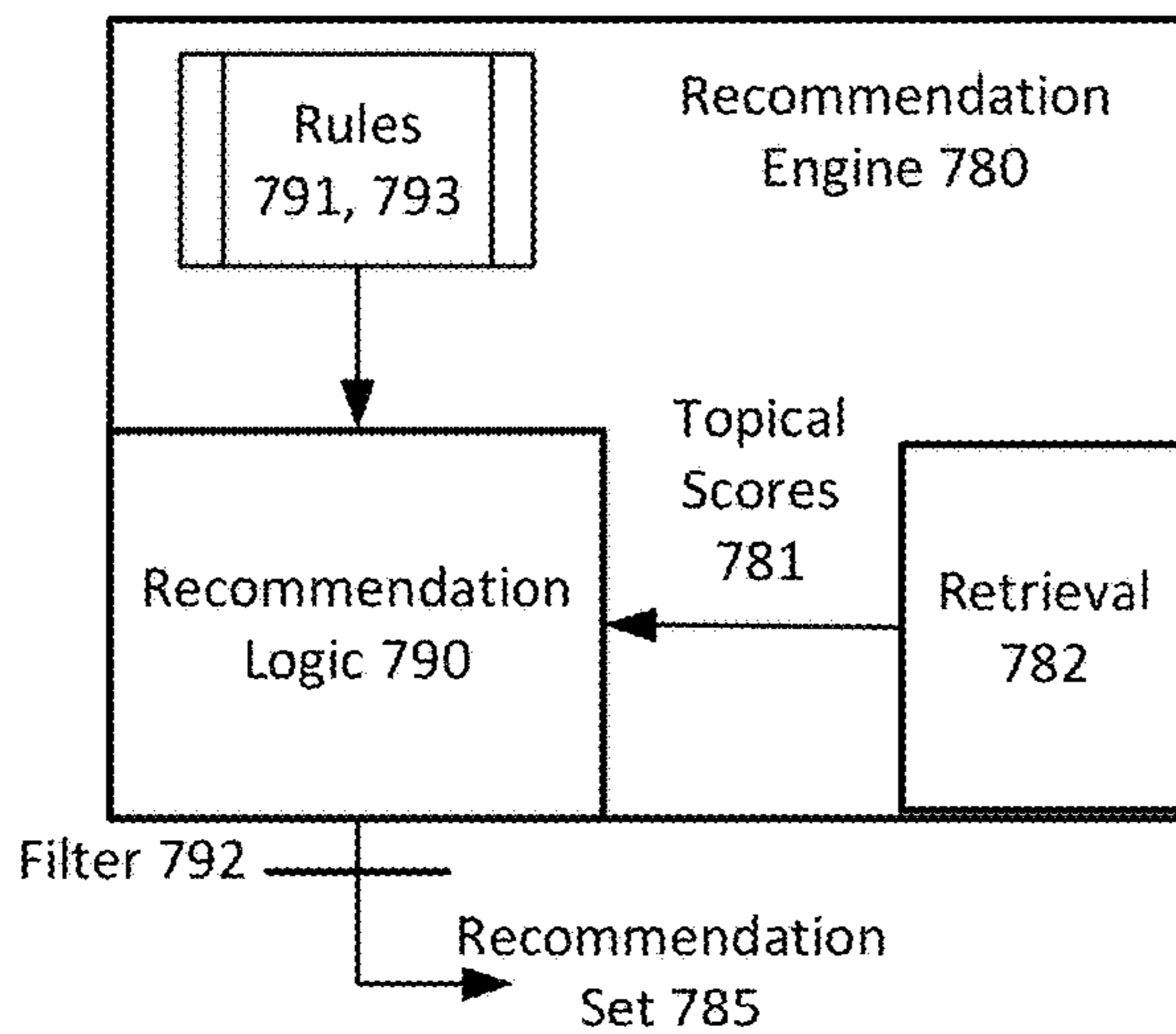
**FIG. 6A**



**FIG. 6B**

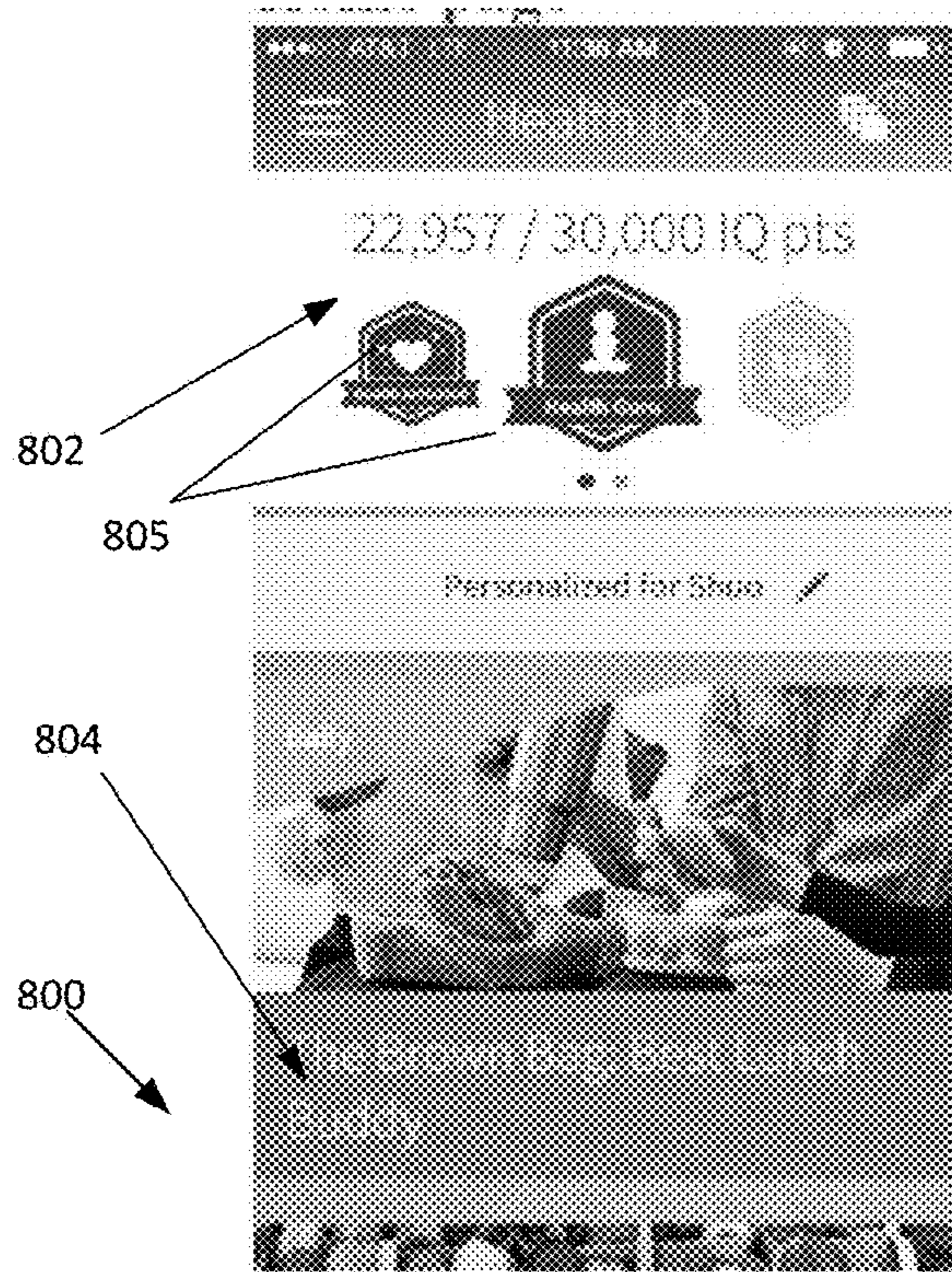


**FIG. 7A**

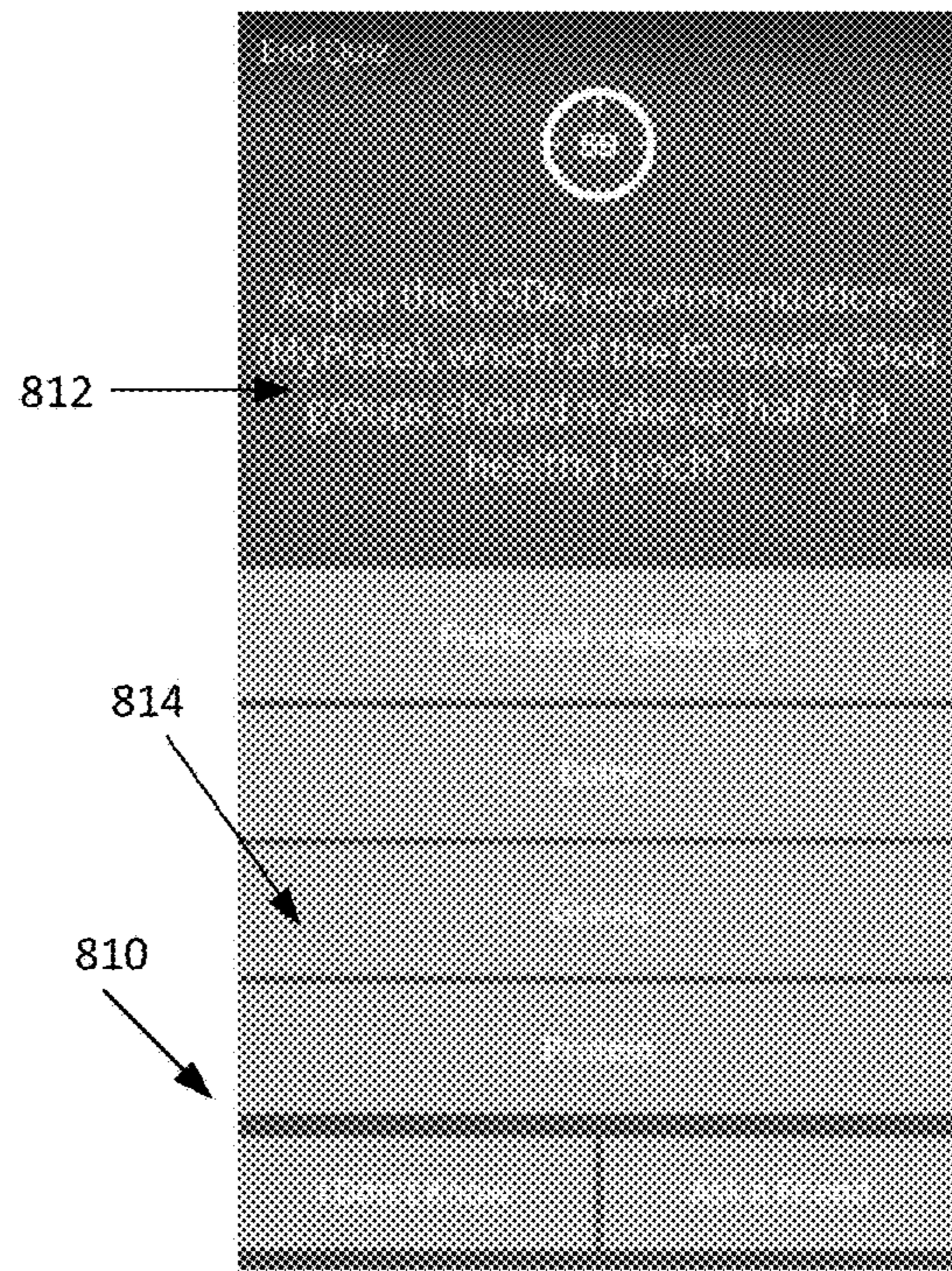


**FIG. 7B**

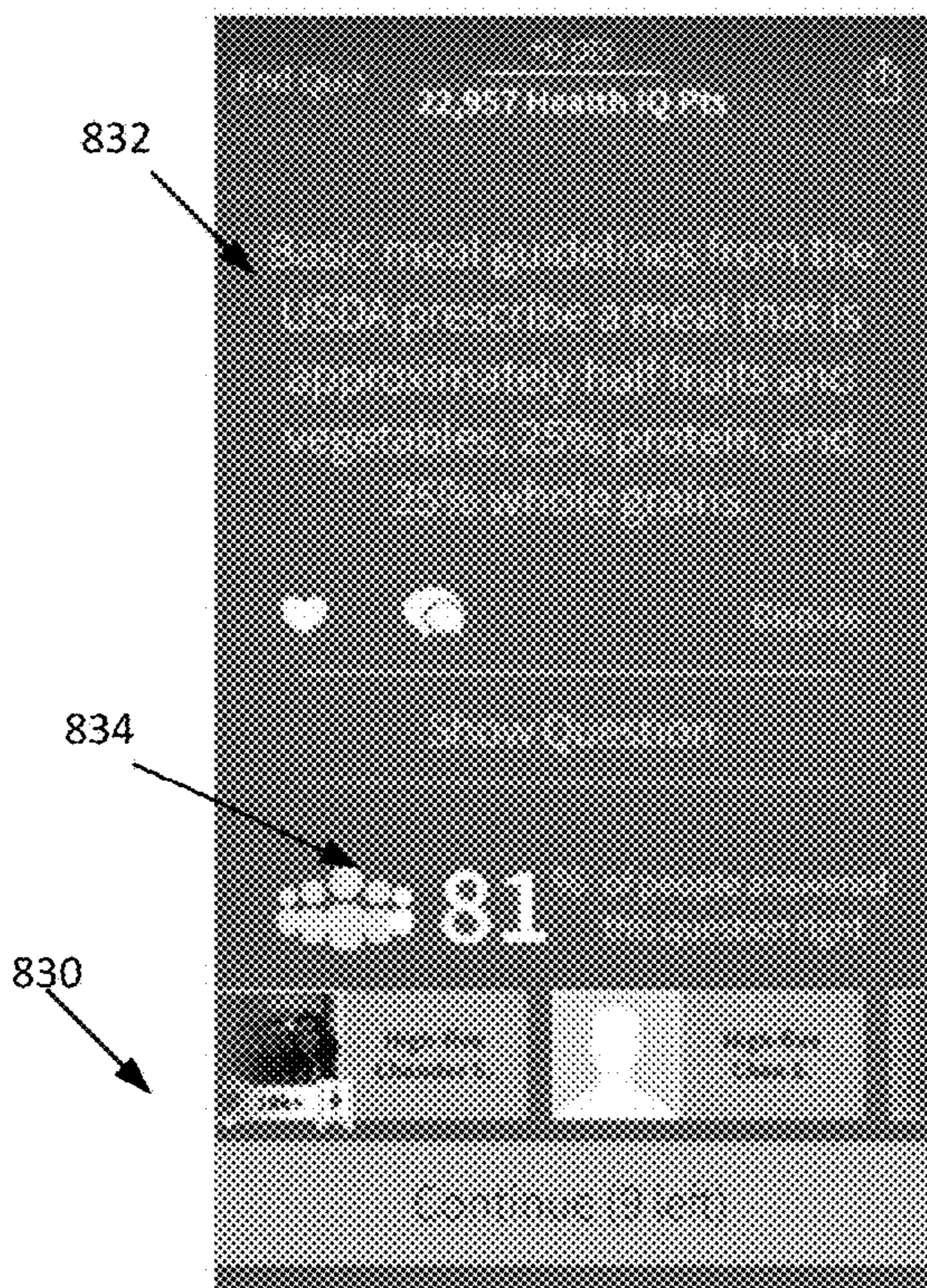




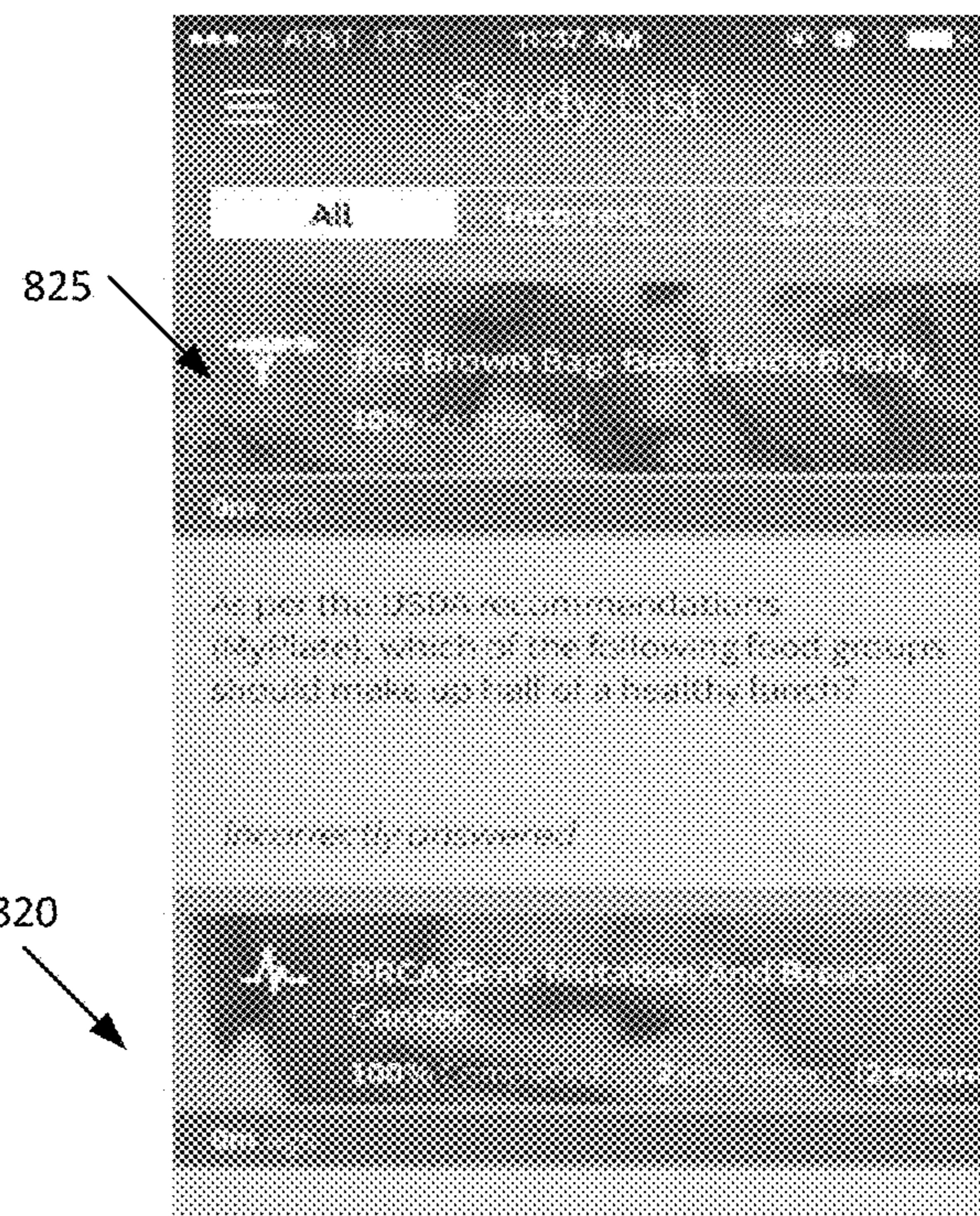
**FIG. 8A**



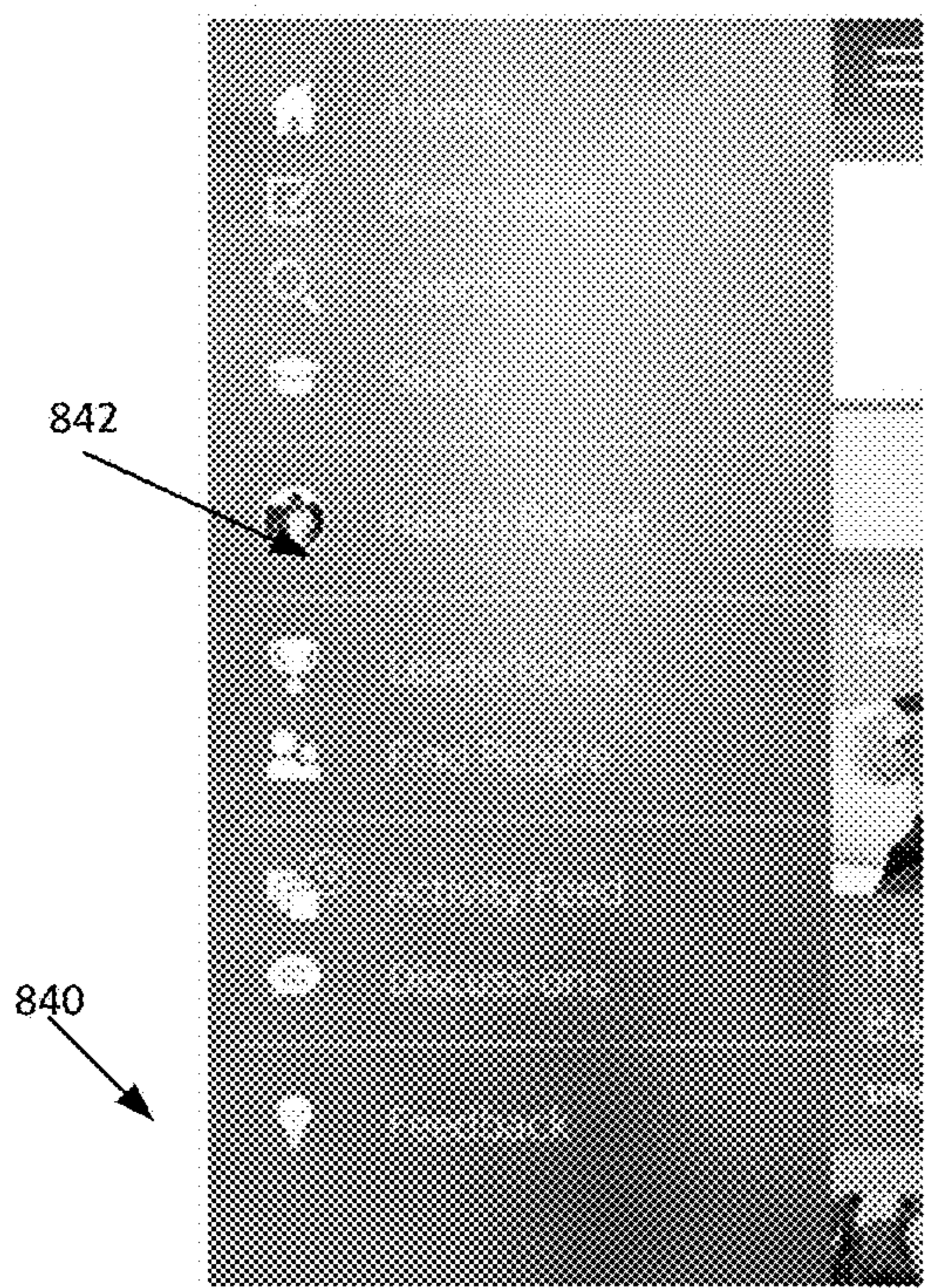
**FIG. 8B**



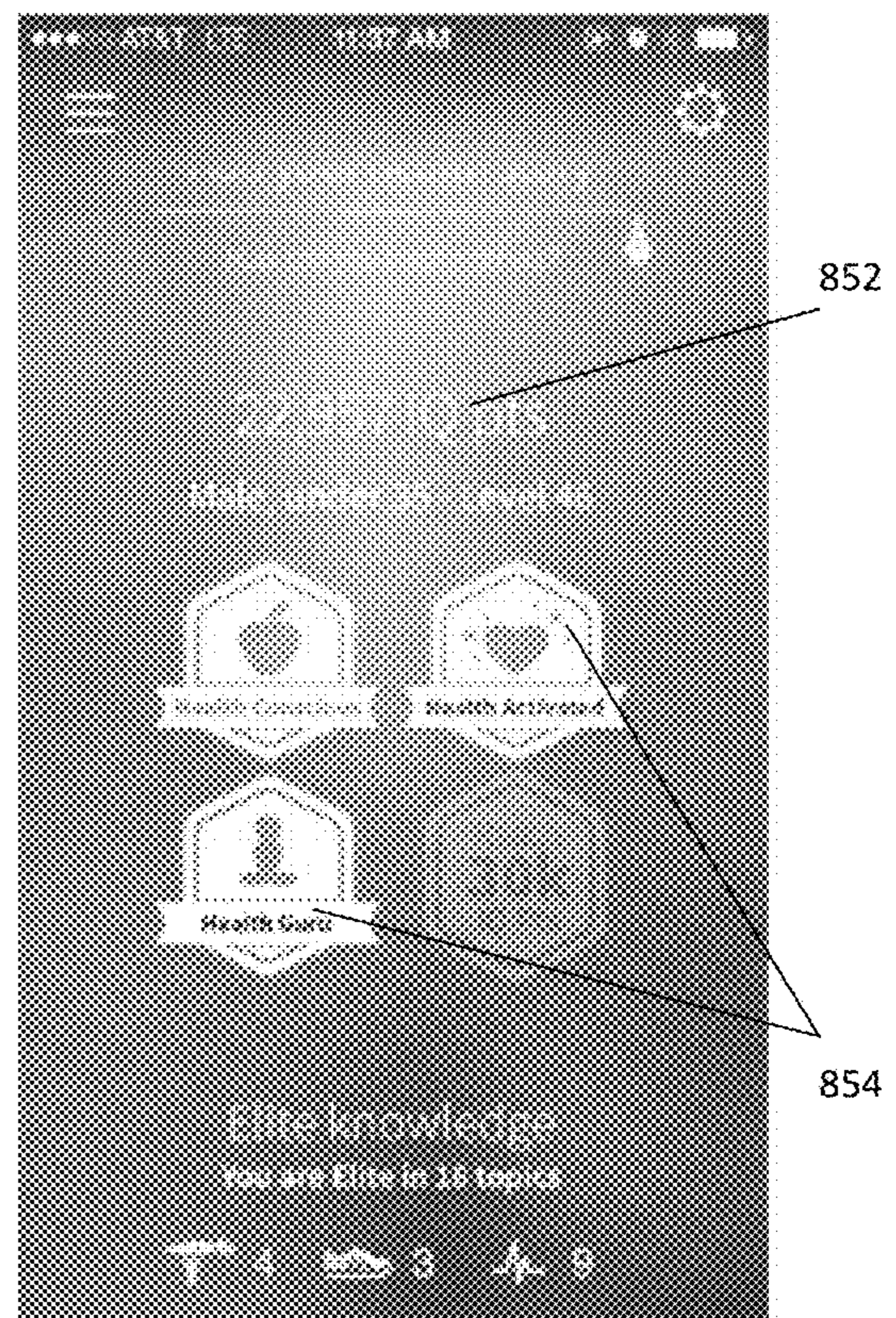
**FIG. 8D**



**FIG. 8C**



**FIG. 8E**



**FIG. 8F**

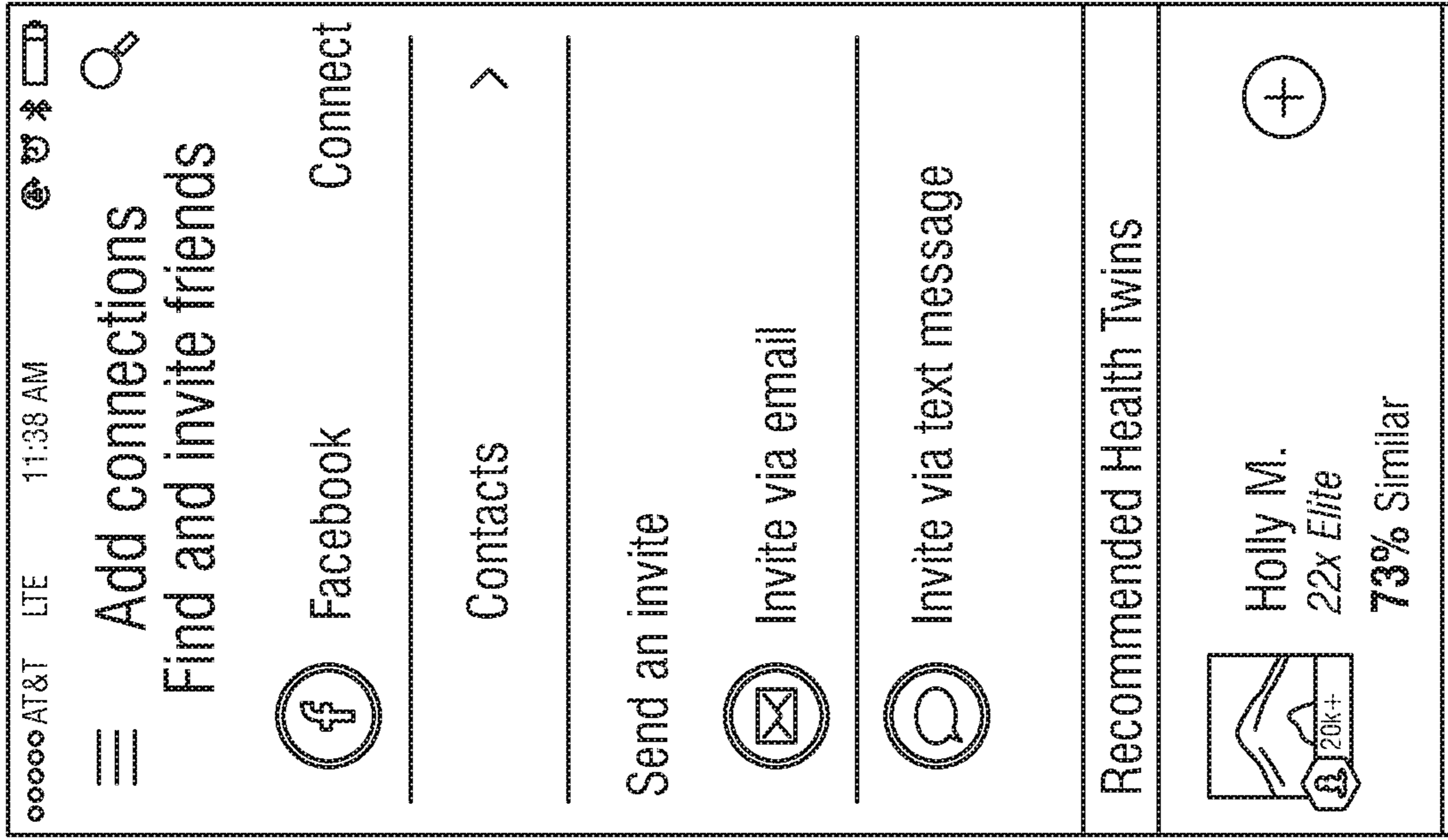


FIG. 8H

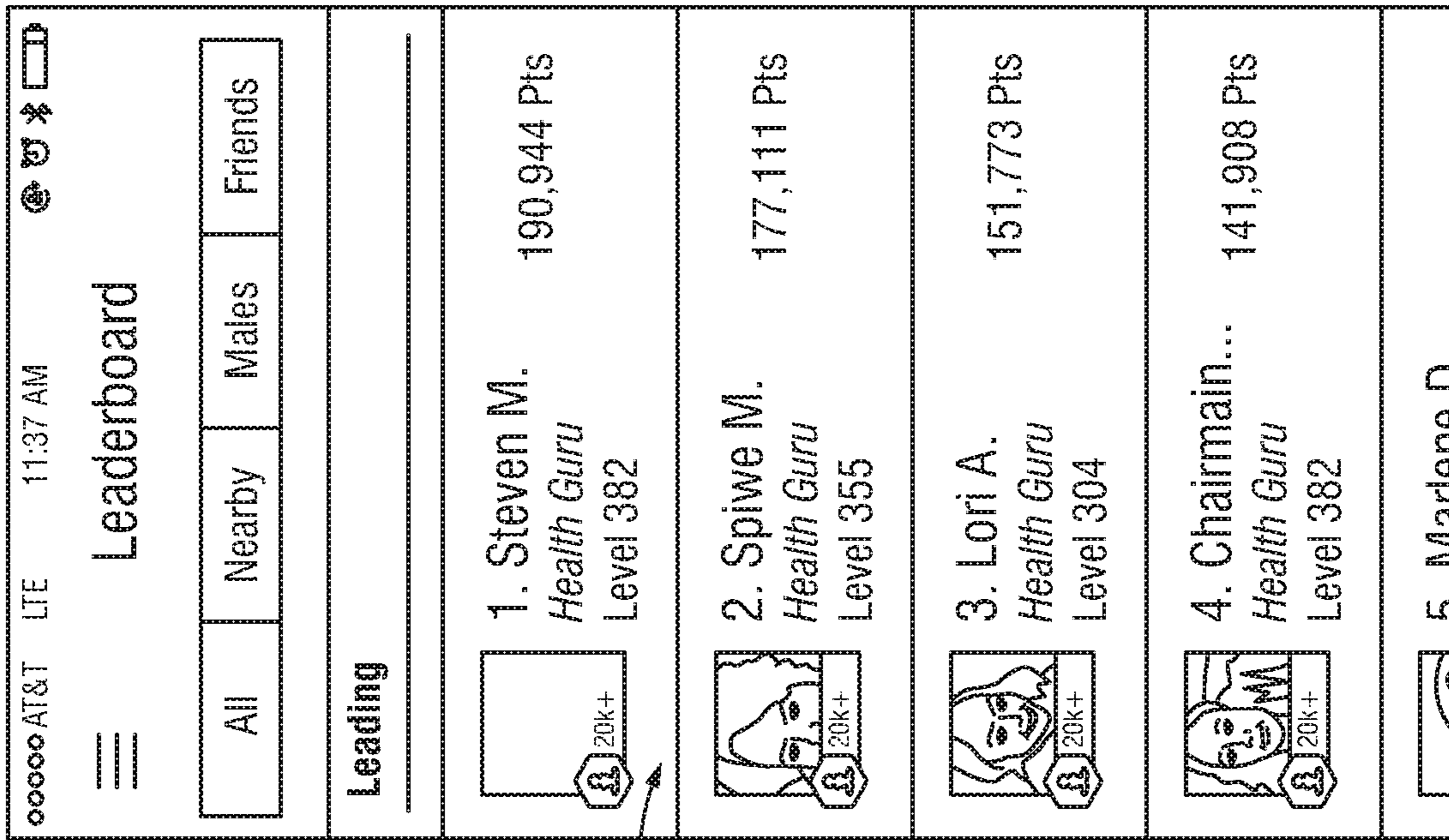
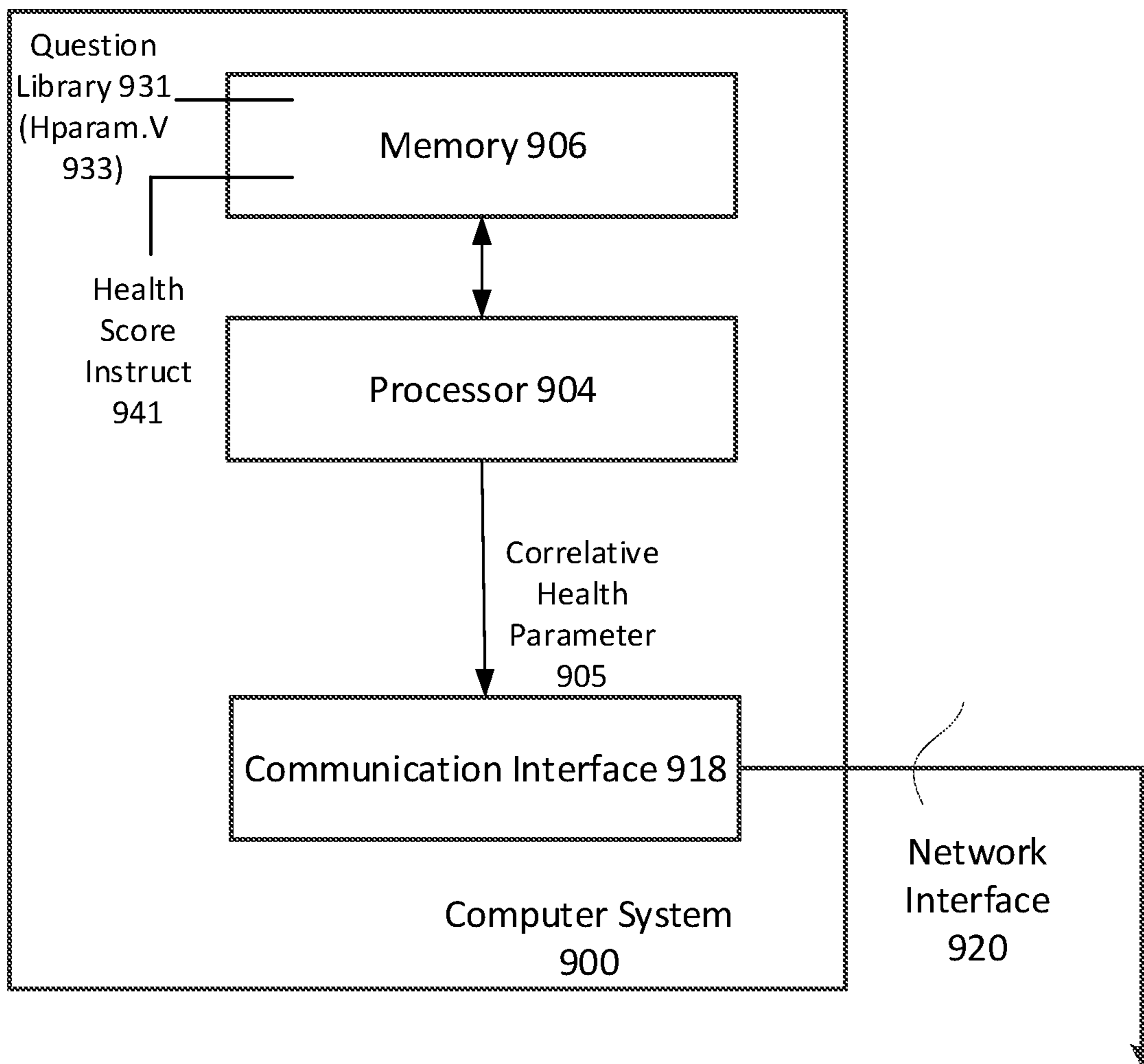


FIG. 8G

870

862

860



**FIG. 9**

1

## SYSTEM AND METHOD FOR DETERMINING AND USING KNOWLEDGE ABOUT HUMAN HEALTH

### TECHNICAL FIELD

Examples described herein relate to a system and method for determining knowledge about human health.

### BACKGROUND

Online services exist which provide interactive gaming and social environments for users. These services generally exist for amusement only.

There also exists a questionnaire, termed the Patient Activation Measure ("PAM"), provided by Insignia Health under license from the State of Oregon, which includes a static set of questions that are knowledge-based and deemed correlative to health.

### BRIEF DESCRIPTION OF THE DRAWINGS

FIG. 1 illustrates a system for predicting a physiological or mental health of a user based on the user's knowledge level of health, according to one or more embodiments.

FIG. 2 illustrates an analysis system, according to an embodiment.

FIG. 3 illustrates an example of a data structure that can be developed to link a question with a health outcome and a topic, according to one or more embodiments.

FIG. 4 illustrates an example method for predicting a health outcome of a user based in part on whether a user has independent knowledge of an assertion relating to health.

FIG. 5 illustrates an example method for predicting a health outcome of a user based on a knowledge profile of a user.

FIG. 6A illustrates an example method for providing a health related service to a user based on a knowledge-predicted health outcome for a user.

FIG. 6B illustrates a health service sub-system 680, according to an embodiment.

FIG. 7A illustrates an example method for providing a game-based environment in which user responses enable prediction of health outcomes for individual users.

FIG. 7B illustrates a knowledge-based recommendation engine, according to one or more embodiments.

FIG. 8A through 8H illustrate example interfaces for use with one or more embodiments described herein.

FIG. 9 is a block diagram that illustrates a computer system upon which embodiments described herein may be implemented.

### DETAILED DESCRIPTION

Some embodiments include a system and method for predicting a health outcome of a user based on a determination of knowledge the user possesses regarding issues of physiological or mental health.

Still further, in some embodiments, a system and method is provided for providing a health service benefit to a user based on their predicted health, as determined from the user's knowledge of human health.

In one embodiment, a collection of assertions are stored in which each assertion pertains to human health. For each individual in a control population of persons, a value of a predetermined health parameter is determined which is indicative of that person's health. For each assertion of the

2

collection, a correlative health parameter is determined which is indicative of an association between those individuals in the control population that have independent knowledge of the assertion and the value of the predetermined health parameter for persons of the control population. The collection of assertions can be stored by associating each assertion with the determined correlative health parameter for that assertion. An interface is provided for a user to indicate the user's independent knowledge of each assertion in at least a subset of assertions from the collection. A health outcome is predicted for the user based at least in part on the correlative health parameter of individual assertions in the subset of assertions.

In still another embodiment, a health outcome of a user is predicted based on a knowledge profile determination of the user. In one embodiment, a knowledge profile is determined for the user which reflects the user's independent knowledge of individual assertions in a collection of assertions. A correlation is determined as between a set of facets of the user's knowledge profile and a corresponding set of facets of multiple individual person's knowledge profile. The knowledge profile can be determined for at least a set of assertions from the collection of assertions. A health outcome is determined for each of the multiple individual persons. The health outcome of the user can then be predicted based in part on the correlation and the health outcome of each of the multiple individuals.

In still another embodiment, a knowledge profile is determined for the user to reflect the user's independent knowledge of individual assertions in a collection of assertions. Each assertion in the collection can be non-specific to the user or to any person of the population, but otherwise known to be correlative to human health. A determination is made as to a first correlation value as between the knowledge profile of the user and a knowledge profile of a control group of persons for whom one or more health outcomes are known. A first health outcome is predicted for the user based on the first correlation value. A health service benefit is provided to the user based at least in part on the predicted health outcome.

Still further, according to another embodiment, a human health knowledge profile is determined for each user in a group of users, the human health knowledge profile reflecting that user's independent knowledge about assertions in a collection of assertions. Each assertion in the collection of assertions may pertain to human health and is non-specific as to any user or to any person of the population. At least a first correlation value is determined as between a facet of the knowledge profile of individual users in the group of users and a corresponding facet of the knowledge profile of a control group of persons for whom one or more health outcomes are known. A subset of one or more users is selected based on the first correlation value of each user of the subset exceeding a threshold designation. A service or designation is provided for a set value to the one or more users of the subset, and not to other users of the group. The service or designation may be associated with a true per-user cost that is not equal to the set value, but which is variable and set to increase over time when individual users in the subset suffer negative health consequences as a result of a naturally progressing medical condition. Still further, some embodiments include a system and method for providing a health service or benefit to a user. By way of examples a health service or benefit can include health insurance (including primary or supplemental), life insurance, enrollment in a facility to receive medical attention, medical publications, as well as discounts or augmented services thereof. In

one embodiment, a collection of questions are stored, where each question is based on a documented assertion pertaining to human health. Each question in a first subset may be associated with a correlative health parameter that is based at least in part on (i) persons in a control population of that have independent knowledge of an assertion that is a basis of that question, and (ii) a value of a predetermined health parameter for each person in the control population the value of the predetermined health parameter for each person being indicative of that person's health. Additionally, the second subset of the questions is associated with a null (i.e. non-existent) or neutral (i.e., not indicative of health) correlative health parameter. A corresponding set of questions is displayed to the user from the collection for response for each user in the set of users. A response score is determined for each user in the set of users based on a correctness of their respective reply to each question in the corresponding set of questions. A health parameter value is determined for at least a health outcome based at least in part on the correlative health parameter of at least some questions in the corresponding set of questions.

Still further, some embodiments include a system and method for providing health recommendations to a user. In an embodiment, a plurality of questions are provided to the user. The plurality of questions can include multiple questions for each of multiple health-related topics, so that individual questions are each associated with one or more of the multiple topics. A score is determined for the user in answering each question in the plurality of questions. The score can include topical scores for one or more of the multiple topics. Based on the topical score of at least a first topic, a set of recommendations can be identified for the user. The set of recommendations may include an action that the user can perform to improve the user's mental or physiological health relating to the topic.

While examples such as described are implemented on computer systems, empirical data has been derived to show health outcome prediction can be correlated to user's knowledge. For example, examples have determined that positive health outcome determinations made from evaluating user's answers directly correlate to fewer hospital stays.

#### System Overview

FIG. 1 illustrates a system for predicting a physiological or mental health of a user based on the user's knowledge level of health, according to one or more embodiments. A system 100 as shown by an example of FIG. 1 can be implemented using a combination of servers, or other computers which combine to provide a network service for client computers operated by a user base. While an example of FIG. 1 illustrates the system 100 being implemented as a combination of logical components, alternative implementations can readily provide for functionality described to be integrated or discrete. Moreover, specific combinations of functionality and processes described can alternatively be performed as sub-combinations or alternative combinations. Likewise, an example of FIG. 1 illustrates use of multiple data stores, which can logically and/or physically be implemented as a combined or integrated data structure (e.g., database), or alternatively, in distributed fashion such as shown.

Among other implementations, system 100 can be accessible to users 11 over a network 101, such as the World Wide Web, to mobile computing devices (e.g., feature phones, tablets, etc.), personal computers (e.g., desktop computers, laptops, etc.) and other user operated computing devices for purpose of interactively engaging individual users to determine their knowledge level on various health topics, and

further for predicting the individual user's physiological or mental health based on their knowledge level of health. Among other advantages, an example of FIG. 1 enables facets of physiological or mental health to be determined for a person, without need for obtaining user specific medical information or biological samples. For example, in one implementation, a user's health can be predicted without use of any user-specific medical question. In a variation, a user's health can be predicted based only on inputs of gender and age.

As described in greater detail, system 100 generates fact-based questions on various topics of health for purpose of (i) obtaining responses from users, and (ii) correlating some of those responses to physiological or mental health determinations. One of the underlying assumptions of system 100 is that the living habits and behaviors of people generally tends to have a measurable impact on their physiological or mental health, particularly when the assumption is applied to a statistically significant sample of people (e.g., hundreds or thousands of persons). Under a statistically significant sample, embodiments described herein have recognized that a correlation can be made as between the knowledge or awareness of individuals and their relative health outcome. More generally, embodiments recognize that health-conscious individuals are generally more knowledgeable about health and also more healthy as compared to less healthy people (e.g., individuals who suffer from obesity, heart disease, etc.). In fact, embodiments recognize that healthy individuals are significantly more conscientious of maintaining healthy living habits and activities, and with this mindset, such individuals are far more knowledgeable about health than the rest of the population.

With this recognition, embodiments described herein provide a system for gauging how conscientious a given user is with respect to health, based on the user's awareness of information that is specific and health driven embodiments further recognize that such. Such information, which in many cases may qualify as trivia, nevertheless provides a mechanism for delineating those individuals in the population who are in fact conscientious about healthy living habits. Furthermore, embodiments described herein programmatically correlate knowledge of health to physiologic health of individuals amongst a statistically significant sample size of users.

In order to gauge knowledge, an embodiment of FIG. 1 maintains a library of fact-based assertions on various subjects of human health, such as nutrition, exercise, medicine, etc. In an example of FIG. 1, the assertions are presented to users in the form of questions, for which responses can provide answers that are either correct or incorrect, and further enable evaluation of knowledge based on whether correct or incorrect answers were given by the users. While examples provide for assertions to be presented to users in the form of questions for purpose of violating their knowledge, other embodiments may use alternative forms of interaction in order to gauge the user's awareness or knowledge of a particular assertion. For example, the user may be provided a statement that is presented as an answer, and the interaction required of the user can be for the user to generate a question that yields the particular answer. In this reverse format, the user's ability to generate the question, combined with a statement as the presented answer, serves as a mechanism for determining whether the user has independent knowledge of the underlying assertion from which the statement was originally presented.

Still further, as described in greater detail, some embodiments utilize a collection of assertions, of which only some

have been determined to correlate to physiological or mental health. The user may have no knowledge of which questions correlate to health, or that only some questions have direct correlation to health while others are being provided for alternative purposes (e.g. amusement). In some cases, the user may even have no knowledge that some of the assertions for which the user is responding to have any correlation to do with their actual physiological or mental health. Among other benefits, the use of many questions, in combination with questions that have been determined to correlate to physiological or mental health, preclude some individuals from ‘gaming’ the questions in a manner that masks their true knowledge level and awareness.

In more detail, system 100 includes a user interface 110, question selection logic 120, response logic 130, and health scoring logic 140. The question selection 120 can receive or access questions 127 from a question library 152, and the user interface 110 can present content based on the selected questions 127 to individual users in any one of a variety of computing environments that stimulate the individual to provide purposeful responses that reflect the user’s understanding and knowledge for a topic of the question. The questions 127 can vary in their purpose. In one example, question library 152 includes (i) a first set of questions 127a which have been correlated to physiological or mental health, and (ii) a second set of questions 127b which have not been correlated to physiological or mental health, but which may serve the alternative purpose of providing trivia, factual information, and/or entertainment. Additionally, the questions of library 152 can be assigned to topics and sub-topics. Still further, the questions of the library 152 can be associated with a difficulty score, based on, for example, a correction rate amongst a control group of persons who answered the question.

When the user initiates a session, the user interface 110 may record a user ID 121 and session information 125. In implementation, the user interface 110 can authenticate the user, and provide credentials 139 for a user profile store 138 in order to obtain profile data 137. The profile data 137 can identify, for example, any one or more of (i) the topic that the user was previously being questioned on, (ii) a topic the user is interested in, (iii) identifiers to questions that the user as previously answered, and/or (iv) a determined knowledge level 135 of the user. With the profile data 137, the user interface 110 can identify parameters or other information for facilitating question selections for the user. In one example, the user interface 110 can use the profile information 137 to specify one or more topical parameters 123 and/or the knowledge level 135 of the user. In turn, the question selection 120 can select questions 127 based on parameters 113, which can be based on, for example, topic parameter 123, knowledge level 135, or user interest and/or preferences.

The profile data 137 can also include user-specific game data 119 (e.g., user’s personalizations for gaming, historical performance on games, current game play state, etc.). Additionally, the profile data 137 can include the user’s community or social network data 117 (user’s personalizations for community or social network application, social network content, etc.). The user-specific game data 119 and community or social network data 117 can, for example, be loaded through the respective functional layers of the user interface 110 when the user initiates a session with a service of system 100.

The user interface 110 can be used to record responses 129 from individual users. In one implementation, each question 127 can be communicated to the user interface

using a sequence in which the answer to the question is also packaged and presented to the user. Some conditional logic may also be provided with the question 127, so that, for example, if the user response is correct, the user is instantly notified and the next question is presented to the user. However, the conditional logic may render an alternative content in response to incorrect user response, specifically a panel or other information item which provides information regarding the actual answer to the question presented. In this way, the user is made more knowledgeable.

The responses 129 can correspond to input that identifies, for example, the user’s answer to a particular question. The responses 129 can identify the answer of the user, the question that was answered, and an identifier of the user. In some implementations, each question 127 can further be associated with one or more subject matter topics. Response logic 130 can process the responses 129 from the various users. In one implementation, an initial determination of response logic 130 is whether the question identified with response 129 is pre-associated with a physiological or mental health correlation, or whether no such pre-association physiological or mental health correlation exists for the question. In one implementation, the response logic 130 records a corresponding response entry 131 for each response, regardless of whether the question of the response has pre-association with physiological or mental health. The response entry 131 can reflect whether the answer to the question is correct, as well as the true answer. In some implementations, the response entry 131 further links the question answered to topical designations for the question, as well as calibration or difficulty scoring.

Scoring logic 144 can process the answer of response entry 131 to determine a score value 145 to associate with the particular record entry. The score value 145 can be based in part on the difficulty level of the question, which in some implementations, is provided as a calibration coefficient that is pre-associated with the question. Thus, the mathematical process to tabulate scoring can include factors such as the number of questions the user correctly answered, the number of questions the user incorrectly answered, the difficulty parameter associated with each question, and/or secondary considerations such as the time it took for the user to provide the response and/or whether the user correctly answered the question on the first try. The score value 145 can be stored with the response data store 118.

Additionally, scoring logic 144 can also tally one or more aggregate or overall scores for the user based on a historical record of responses. For example, the response data store 118 can maintain one or more aggregate or ongoing subject matter topical scores (e.g., weight-lifting), as well as an overall score for the user. As described with other examples, scoring logic 144 can be used to develop comparative scoring as between users, based on her overall knowledge, session performance, and/or topical subject matter knowledge.

The response logic 130 can optionally include a knowledge level determination component 134. The knowledge level determination component 134 can determine from the response 129 the knowledge level 135 of the user. Alternatively, the knowledge determination component 134 can determine the knowledge level of the user from the difficulty parameter associated with the question and/or with the score output, as provided by the scoring component 144. The knowledge level determination component 134 can determine an overall knowledge level or a topic-specific knowledge level 135. The determined knowledge level(s) 135 can be stored as part of the user profile 138, so that the

knowledge level of the user is communicated to the questions selection logic **120** when the user initiates a session with system **100**.

For those selected questions which are identified as having a pre-associated physiological or mental health correlation, the response logic **130** can provide a corresponding health question record **133** which identifies, for example, the question, the answer provided, and/or whether the question was answered correctly. The health question record **133** can also specify a topic or topics of the question.

According to some embodiments, the question identified with the health question record **133** can be associated with a health parameter value **151**. As described by other examples, the health parameter value **151** can be determined as part of a correlative model that is developed using a control population in order to provide a quantified correlation to physiological or mental health. A health scoring data store **150** can maintain a collection of health parameter values **151** for individual questions. In one implementation, the health parameter values **151** reflect a predefined health outcome. Multiple health outcomes can be considered, and each question of health question record **133** can be associated with a particular health outcome. By way of examples, the possible health outcomes that have quantifiable correlations to the health parameter values **151** include (i) health care cost for an individual in a given time period, (ii) number of medical facility visits by an individual in a given time period, (iii) number of prescriptions that the person takes in a given time period, and/or (iv) number of sick days that the person took. Other examples of health outcomes include propensity for cancer (including cancer of different types), heart disease, diabetes, hypertension or other afflictions. The health outcomes can thus be numerical and continuous in nature (e.g., health care cost) or categorical (e.g., number of medical visits, prescriptions, sick days).

Accordingly, in one implementation, the health scoring component **140** utilizes health outcome logic **142** generates a health outcome score **165** that is specific to a particular health outcome definition **155**. The health outcome logic **142** can be implemented as a formula or model, and can take into account parameters that include the health parameter value **151** determined an answered question, the number of questions answered, the time of involvement, etc. In one implementation, the health parameter values **151** that can be combined or tabulated can be determined from identifying the health questions **141** and responses **143** of the user. Based on the question and response the health correlative parameters **151** are retrieved.

In an embodiment, the health scoring component **140** uses the health correlation parameter **151**, as well as the question **141** and response **143** to predict the health outcome **165** of the user. In determining the health outcome, the health scoring component **140** can use a model or formula to determine the health output score **165**. For example, the health scoring component **140** can map the user's input to a health score output which is then predictive for the user. The model used by the scoring component **140** to predict the health outcome score **165** of the user can be the same model which determines the correlation of questions to the particular health outcome definition. Examples of such models is provided with FIG. 2.

The health outcome score **165** can be generated and stored as part of the user health data store **160**. Additionally, the health outcome score **165** can be specific to a particular health outcome, and the type of value it reflects can be specific to the health outcome type. For example, one implementation provides that for a health outcome that

reflects health care cost for the individual, the health outcome score **165** can be numeric indication of a specific cost or range of costs for the individual. The health outcome score **165** for the number of medical facility visits, on the other hand, can be reflected by a category or level (e.g., 1 to 5 depending on amount).

In one implementation, the user health data store **160** is maintained logically or physically separate from the question response data store **118** in order to preclude its viewability to users of system **100**. Each user can include a profile of health outcome scores with the user health data store **160**, with individual user profiles **141** which include scores for multiple different health outcomes. In some variations, a combined score or category may also be given to individual users as part of their health profile.

As described with other embodiments, the health outcome score(s) **165** of the user can be made available for health services, such as health insurance services. For example, the premium, deductible or scope of coverage provided as part of a health insurance package for a user can be determined from the health outcome score(s) **165**. As another feature, health outcome score(s) **165** of the user can be used to determine if the user should receive a discount for health insurance, or alternatively receive an added benefit from health related services that are provided (or are to be provided) to the user.

According to one embodiment, a health service **190** sub-system can utilize the health outcome scores **165** provided in the user health database **160** to determine designations, qualifications or service level, in connection with a health-related service. Examples of health related services **190** include health insurance, life insurance, health service plans, memberships in health related facilities (e.g., health spas, medical office), informational services (e.g., magazine or journal subscriptions, electronic news). The benefit that can be provided to the user includes the service itself, or alternatively a designation of health for use with such a service. For example, the user's predicted level of health can be determined by the health outcome score(s) **165**, and this can result in an overall health outcome determination (e.g., a ranking or classification), which in turn can be used to receive a discount for health related services (e.g., discount on health or life insurance premium, expanded coverage, etc.). An example of health service sub-system is provided with an example of FIG. 6B.

In some implementations, the user interface **110** of system **100** can include various layers or functional components for enhancing the interactivity level of the user. In one implementation, the user interface **110** includes a gamification layer **112** and a community social network layer **114**. The gamification layer **112** includes logic, data, and content (collectively "game data **103**") for implementing a competitive environment for which the individual is to supply answers for questions **127**. The game data **103** can be generated a gaming engine **115**, which can further personalize the gaming environment for the specific user. For example, the user identifier **121** can be used by a gaming engine **115** to generate user-specific game data **103**. The game data **103** can, for example, include a competitive environment that is based on the knowledge level of the user and/or topical interests of the user. An implementation that utilizes a gamification layer **112** is described with FIG. 7A. The gamification layer **112** can determine awards or credentials (e.g., skill level badges) for the user based on their performance. By way of example, the questions **127** presented through the user interface **110** can be associated with a score value that accounts for difficulty (which may be



determined from a calibration process, as detailed below), response time, handicaps (e.g., the age of the user), etc.

The community social network layer **114** can operate using community data **117**, which can be generated from a community/social network service **116**. The community/ 5 social network service **116** can, for example, provide user-specific community (or social network) data based on the user identifier **121**. The community data **117** can provide content (e.g., user's health interest or knowledge specialties) that is provided as part of the community social network layer **114**. 10

The health parameter value **151** represents a correlative and quantified measure as between human health and knowledge of a particular assertion. The granularity of the health parameter value **151** is applied to a question as answered 15 from an individual, but the determination of the value can be based on a correlative model applied to a control population of users. The control population of users include those individuals who, for example, voluntarily provide real-world information about themselves, and more specifically, 20 actual health outcomes in a recent duration of time.

In more detail, system **100** can include a question analysis sub-system **170** that includes functionality for determining correlations between knowledge of individual questions and actual health outcomes. The sub-system **170** can implement and develop one or more correlative models **172**, which can 25 analyze input questions **171** for purpose of determining correlations to health outcomes. In particular, the correlative models can be implemented for purpose of determining health parameter values **149** that statistically reflect a correlation as between knowledge of individuals in the control population (shown with the control population data store **180**) for particular question and the respective health out- 30 comes for those individuals who answered the question (either correctly or incorrectly, depending on implementation). The health correlative values **151** can be specific to individual questions or cluster of questions. In one implementation, different correlative models **172** can be used for different types of health outcomes. Different correlative models may compare a predicted value with actual (or 40 real-world) data provided for individuals (shown as verified input **175**). An example of question analysis sub-system is described in more detail with an example of FIG. 2.

While numerous examples provide for use of health correlative scores, other embodiments can also generate 45 recommendations to users based on their overall knowledge level, as determined by, for example, the user's score, or topic-specific scores. A response analysis **164** can retrieve scores **145** from the response database **118**, for example, and generate recommendations, content or other output based on the user scores. An example of response analysis **164** is 50 illustrated with FIG. 7B, and accompanying examples thereof.

As an addition or alternative, the community social network layer **114** can provide forums such as message boards, 55 ask an expert, or topical walls for shared information and experiences. In one implementation, credentials that the user earns through the gamification layer **112** are carried onto the social environment of the community social network layer **114**. For example, an 'expert level' user may have credence 60 when responding to questions of others, even to a point where the user can request payment or other consideration for providing answers or information to other users.

FIG. 2 illustrates an analysis system, according to an embodiment. In particular, FIG. 2 illustrates an analysis 65 system **200** for analyzing questions (or other forms of assertions) for purpose of determining whether knowledge

of the underlying assertions by subjects can be correlated to physiological or mental health of the subjects. According to some embodiments, individual questions, or alternatively groups of questions, can be correlated to a quantifiable 5 metric that statistically relates a subject's knowledge (or lack of knowledge) for an underlying assertion to a likelihood of a particular health outcome. The system **200** can be implemented as, for example, a sub-system of a physiological/mental predictive system **100**, such as shown with an example of FIG. 1. 10

In more detail, system **200** includes a question intake interface **210**, a fielder **220**, a calibration component **230**, and a correlative model implementation component **250**. A question interface can receive questions **209** through, for 15 example, a manual interface (e.g., experts generate questions based on health assertions). The questions **209** can be manually associated with one or more topics relating to human health, such as topics relating to nutrition or exercise, or specific medical conditions. The granularity of the topics 20 **211** can be determined by implementation. A question store **215** can be used to store a question **209** for processing as the question is calibrated and/or correlated to human health.

The fielder **220** includes functionality to distribute the questions **209** to a control population of users through a 25 population interface **222**. For example, the fielder **220** can issue questions using the user interface **110** of an example system of FIG. 1. For example, with further reference to an example of FIG. 1, questions **209** can be issued through 30 gameplay of user interface **110**, and responses from various users can be recorded. Some users, however, can be designated as belonging to the control group. These users can correspond to individuals for which data corresponding to ground truth data exists. For example, many users can be 35 given an opportunity to volunteer real-world health information. Such users can be asked questions such as "how many doctor visits did you have last year" or "how many sick days did you have last year." Still further, some information like the user's health insurance cost can be obtained from a source such as the insurance companies. Accordingly, 40 in one example such as shown by FIG. 1, members of the control group can supply responses **213** to questions **209**, presented through a game. At a separate time, either before or after the questions **209** is presented to the subject, the subject can also be given the choice to provide actual data, 45 shown as true user data **241**. The true user data **241** can represent an actual health outcome of a subject providing the response **213**. The true user data **241** can include information manually supplied by the subject, as well as information provided by, for example, an insurance carrier of the subject. 50 Each response **213** from one of the subjects of the control population (e.g., those users of system **100** who opt-in to provide information) can be linked to the question and to the identifier **205** of the subject. Additionally, the true user data **241** can be linked to the user identifier **205** of the subject 55 providing the response.

The calibration component **230** can analyze the questions **209** under process to determine a difficulty level **265** of the question. For example, the calibration component **230** can query **231** the intake store **215** for a tally of the number of 60 responses which were correct and incorrect. The percentage of individuals who correctly answer a question can provide a basis for determining a difficulty level of the question. The difficulty level **265** can be stored with the question for subsequent use.

The correlation model **250** operates to determine a correlation between knowledge by a subject for an underlying 65 assertion of a question and the subject's health. In one

implementation, the correlation model **250** implements one or multiple models for purpose of determining different parametric values that statistically correlate to different health outcome definitions (e.g., amount of healthcare or healthcare cost an individual requires, the number of medical facility visits, propensity for heart disease, cancer, hypertension or diabetes, etc.). The correlation model **250** can receive, as model input **255**, (i) a question identifier **261**, (ii) identification of a set of individuals in the control group who answered the question **209**, including identification of the answer each person provided to the question **209**, and (iii) true user data **241** for each person in the set of individuals that answered the question. The particular model selected compares an expected result to a true result by (i) assigning the person to an expected result, corresponding to a particular health parameter value, based on their answer to a question, then (ii) using the true user data **241** to compare a true health outcome (reflecting real-world data of the individual supplying the answer) to the expected result.

The expected result can initially start as a hypothetical or neutral value, indicating a likelihood that a given person has or does not have a particular health outcome based on the answer the person provided to the question. The expected result can further include different values depending on whether the user provided a correct answer or incorrect answer, as well as which incorrect answer the user provided. The initial correlation can correspond to a coefficient (e.g., a value between 0 and 1) that is set by, for example, an expectation as to whether the underlying assertion of the question is information that is indicative of health-conscious behavior (e.g., rubbing one's eyes can make a person susceptible to common cold) or information that is indicative of poor health-conscious behavior (e.g., specific nutritional information about a donut). From the initial value, the correlation can become positive, negative or made neutral based on the expected/actual comparison for persons in the set. As more individuals are added to the set, the correlation can be made more valid or certain. The determined correlation from the correlation model **250** can be identified as correlative health parameter **251**. The correlative health parameter **251** can be specific to a particular health outcome **253**. The correlative health parameter **251** can, for example, correspond to a parametric value, such as a weight or coefficient, which can be aggregated, modeled and/or combined with other parametric values to make a health outcome determination.

The particular model **255** implemented by correlation model **250** can depend on the nature of the health outcome that the assertion is to apply to. For a health outcome definition in which the health parameter value is continuous (e.g., monetary cost for health care in a given period, weight or body mass index), a linear regression model can be used. Some health outcome definitions can utilize health parameter values which are tiered or categorical. For example, the number of medical facility visits can be defined into tiered values, such as: 0=no medical facility visits, 1=1-2 medical facility visits in a year, 2=3-5 medical facility visits in a year, or 4=5 or more medical facility visits in a year. Similar tiered values can be used for health outcomes such as sick days. For such health outcomes, an ordinal logistic regression model can be used. In variations, a multinomial or polynomial model can be used for tiered categories, particularly those health outcomes which define tiers which are not naturally ordered. Each question can be assigned to a particular health outcome, so that the health parameter value is specific to the determination of the health outcome.

Numerous other machine-learning models can be used in both developing correlative health parameters, and determining health outcomes based on correlative health parameters. By way of example, such machine-learning models can include random forest, neural network and/or gradient boosting models.

In some embodiments, the determination of the health parameter values **251** can be tuned to reflect determinations that are for use with a model in which no user-specific information is known. In one implementation, the control population can be associated with classification parameters, such as age group (e.g., over 50, under 50), gender, weight, race, geographic location or setting, and/or presence of certain medical conditions such as diabetes. An individual question can be associated with multiple correlative health parameter values **251**, including health parameter values that reflect the general control population, as well as a health parameter value that is specific to a class or sub-class (e.g., females over 50).

According to some embodiments, a combination of question and correlative health values **251** can map to one of multiple possible health outcomes. Thus, in one implementation, a question can have a correlative health value as it applies to a single health outcome.

Other implementations provide for the determination of health parameter values **251** which are correlative to health of a user based on a model in which a classification (e.g., gender or age) or set of classifications (e.g., gender and age) are known about the person answering the question. Depending on implementation, the classifications of users can include (i) unknown users, for which no information is known, (ii) users for which some basic health-relevant characteristic is known, such as age, gender, or combination thereof, (iii) users for which multiple relevant facets of health is known, such as their weight and/or height, as well as, as gender and age. One implementation provides for the determination of correlative health parameters **251** which are determined specific for different classifications of the user, based on applying models as described to segments of the control population which have the relevant classification. Thus, in some variations, the correlative health parameter values **251** can be made specific to specific classes of persons, so that the evaluation of health for the user is made in reference to the user's class. For example, in some embodiments, the questions can be fielded for individuals who categorize themselves by gender, age, weight, and/or presence of certain medical conditions such as diabetes.

System **200** can be implemented on a control group that is dynamic, meaning individuals can be added to the control group continuously over time. As mentioned, a larger control group can provide more valid results. In an interactive gaming environment, such as described with an example of FIG. 1, additional persons can be added to the control group continuously through invitation or opt-in features. For example, the user-interface **110** can prompt individuals to volunteer for questions that reflect actual medically relevant information. This mechanism can provide a way to expand the control group with the addition of users for whom true user data **241** can be provided. The control group can also be managed based on criteria, such as gender and age, so that it accurately reflects a desired population segment.

With the determination of the health parameter values **251**, the questions can be deemed processed, in which case the questions can be included in a library or collection of questions and marked as being correlative to health. In one implementation, a library build process **260** link processed questions **259** with the question identifier **261**, topical iden-

tifier **263**, the difficulty level **265** and the correlative health parameter **251** (or multiple values). The difficulty level **265** can be used to determine which individuals receive the question based on user level.

While an example of FIG. 2 provides for processing of questions which are deemed correlative to health, a fielding and calibration process can be used to determine difficulty of all questions, including those questions which have no determined correlation to health. For example, any question can be associated with the topic **211** and fielded to the control population as described, and further evaluated for difficulty level **265** based on, for example, the percentage of individuals of the control group who correctly answered the question.

FIG. 3 illustrates an example of a data structure that can be developed to link a question with a health outcome and a topic, according to one or more embodiments. While an example of FIG. 3 illustrates the data structure **300** as being logically integrated, variations can provide for distributed data structures which associate or link parameters as described. With reference to an example of FIG. 1, the data structure **300** of an example of FIG. 3 can, for example, be provided with the question library **152**, and include information provided with the health scoring database **150**.

In more detail, data structure **300** associates individual questions by question identifier **301** to one of multiple possible correlative health parameters **303**, and one or more topics **305**. Other information or parameters that can be conveyed with the data structure **300** include a difficulty level, which can be determined, for example, through an output of the calibration component **230** (see FIG. 2). For a given implementation, the correlative health parameter can relate to a particular health outcome. Multiple health outcomes can be defined for a future time interval, including health care cost, medical facility visits, sick days, and number of prescriptions. Other examples of health outcomes include blood sugar level, weight or body fat (e.g., BMI), cholesterol level, depression or anxiety disorder, and/or longevity. In one embodiment, each question associated to only one health outcome, and is further assigned a correlative health parameter value that reflects a correlative measure between knowledge of the underlying assertion and a corresponding health outcome. In one implementation, a system of FIG. 2 determines health parameter values for each defined health outcome, and the health parameter value selected for a question is that which has the strongest correlation. If no correlative health determination has been made for a question, then the health parameter values for such questions can be shown as null.

As further shown by an example of FIG. 3, each question can be linked with multiple topics based on, for example, manual input. The determined difficulty can also be expressed as a parameter, such as a number between 0 and 1. The difficulty level can be independent of the topic assignment for the question—thus, meaning the difficulty level of a question can be provided as being the same regardless of the assigned topic being considered.

#### Methodology

FIG. 4 illustrates an example method for predicting a health outcome of a user based in part on whether a user has independent knowledge of an assertion relating to health. FIG. 5 illustrates an example method for predicting a health outcome of a user based on a knowledge profile of a user. In describing example methods of FIG. 4 and FIG. 5, reference may be made to elements of FIG. 1, FIG. 2 or FIG. 3 for purpose of illustrating a suitable component for performing a step or sub-step being described.

With reference to an example of FIG. 4, a collection of assertions relating to human health can be stored and processed for use with a population of users (**410**). In one implementation, the assertions can be formatted as questions for which the answer from the user indicates whether the user has knowledge of the assertion (**412**).

For the control population, a health parameter value is determined for individuals of the control population (**420**). The health parameter value can reference actual or real-world data which serves as an indicator of physiological or mental health of a user. In one implementation, the determination of the health parameter value can be based on input of a user. For example, in an interactive gaming environment of FIG. 1, some users can opt-in to provide requested health-specific input, such as the number of sick days taken in the prior month or year. In some embodiments, the health parameter value is based on a defined health outcome (**422**), or combinations of health outcomes. By way of example, the health outcome can correspond to an estimated health care cost for an individual (**424**), a number of medical center visits for an individual in a given duration of time (**425**), a number of prescriptions for the individual in the given time frame (**426**), and a number of sick days an individual incurred in the given duration of time (**428**).

For each assertion, a correlative health parameter is determined (**430**). Generally, the correlative health parameter corresponds to a parametric measure that quantifiably links knowledge of an assertion to human health. The health parameter value **151** (FIG. 1), **251** (FIG. 2), as described with other examples, provides an example based on use of a control group (**432**).

The establishment of questions with associated correlative health parameters can be done through implementation of a model, with ground truth data provided by select users from a larger user base of respondents. Once the correlative health parameters are established for individual questions, the questions can be fielded to the user base. The responses from the user can be used to determine the user's independent knowledge level of a particular assertion (**440**).

The correlative health parameters for the individual questions answered by the user can be determined and modeled into a value for a particular health outcome (**450**). For each user, the correlative health parameters of the answered questions pertaining to a particular health outcome can serve as inputs in order to determine a predicted health outcome for the user (**460**). Multiple health outcomes can be determined in this manner.

With reference to FIG. 5, a knowledge profile of a user can be determined, relating to a particular health outcome (**510**). The knowledge profile can reflect answers to individual questions, or answers to clusters or groups of questions. The knowledge profile can be determined based on a selected definition. In one implementation, the knowledge profile is specific to a question, and reflects whether a user correctly answer the question. In a variation, the knowledge profile is specific to a question, and reflects which question the user answered. Still further, the knowledge profile can reflect the user's answers in aggregate form, such as in a cluster of questions (e.g., 3 to 10 questions), reflecting facets such as the number of questions the user correctly answered in the cluster, or the number of answers provided which were deemed more wrong than others.

A facet of the knowledge profile can be compared to corresponding facets of knowledge profiles from individuals of a control group (**520**). In one implementation, the user's answer to a particular set of questions can be individually compared to an answer to the same set of questions from one

or multiple persons of the control group. In variations, the user's answer to a cluster of questions can be compared to answers provided by a subset of the control group for the same cluster of questions, with the comparison being made for the cluster of questions as a whole. Still further, the user's answers can be compared to answers provided by a subset of the control group which provided the same exact answers for the cluster of questions.

A health outcome can be determined for individuals of the control group (530). As mentioned with other examples, the health outcome can be defined as a healthy living style characteristic that is indicative of human health. The health outcome that is determined for a person of the control group can reflect real-world information about that person (532). In one implementation, individuals of the control group can volunteer their personal health outcome information (534). For example, the information can be provided in exchange for some benefit to the person of the control group. In variations, the health outcomes information for persons of the control group can be determined from sources such as health care or insurance providers (536).

The health outcome of a user can be predicted based in part on a correlation between the health outcomes of individuals in the control population and the compared facets of the knowledge profile between the user and persons of the control group (540). Thus for example, a user's answer to individual questions can be compared to the answers provided for the same questions by those members of the control group. As an addition or alternative, a user's answers to a cluster of questions can be compared to answers provided to the same cluster of questions for individuals of the control group, with, for example, the comparison being based on matching the user with a subset of persons of the control group based on a percentage of correct or incorrect answers provided.

#### Health Service Methodology and Sub-System

FIG. 6A illustrates an example method for providing a health related service to a user based on a knowledge-predicted health outcome for a user. In describing example method of FIG. 6A, reference may be made to elements of FIG. 1, FIG. 2 or FIG. 3 for purpose of illustrating a suitable component for performing a step or sub-step being described.

With reference to FIG. 6A, a health knowledge profile is determined from each of multiple users (610) with regard to assertions relating to health (e.g., physiological or mental health). As mentioned with other examples, the health knowledge profile can reflect individual answers to questions, those questions which were answered correctly or incorrectly, specific answers provided to specific questions (e.g., such as incorrect answers), and/or percentages of questions answered from a defined cluster of questions.

Additionally, as mentioned with other examples, a value of a health correlation parameter can be determined as between the user and a subset of persons in the control group (620). With reference to an example of FIG. 1, the health value parameter 151 can, for example, be determined by the health scoring component 140. In determining the health correlation parameter, a given facet of the users' knowledge profile can be compared to that of relevant persons in the control group (622). By way of example, the comparison can be on a question by question basis, or alternatively, on a cluster basis (e.g., compare set of 5 answers, etc.). Actual health outcomes can be known for members of the control group, and the identified correlative health parameters can be based in part on the known health parameters of individuals in the control group. The correlative health param-

eter can thus be pre-determined for the control group, and based on real-world information about members of the control group.

Based on the correlation values, a health outcome determination is provided for the user (630). As shown with an example of FIG. 3, the correlation values can be specific to pre-determined health outcomes. Further with reference to an example of FIG. 1, given a set of health parameter values 151 for a particular health outcome, the health scoring component 140 can make a health outcome determination. The determination of the health outcome can be in the form of a score, so that it gives a relative measure of the particular health outcome as compared to other individuals in the general population. The health outcome determination can correspond to a health outcome score 165, or alternatively, to a combination of health outcome scores. For example, multiple health outcome scores can be determined for the user, and the scores can be combined to form an aggregate health outcome determination.

Based on the health outcome determination, a health service benefit can be provided to the user (640). The service or designation can be one made for a set value, wherein the service or designation is associated with a true per-user cost that is not equal to the set value, but which is variable and set to increase over time when individual users in the subset suffer negative health consequences as a result of a naturally progressing medical condition.

The health service benefit can correspond to a variety of direct and indirect service related benefits. In one implementation, those users with a health outcome determination that exceeds a particular threshold can receive a designation (642). The designation can correspond to a service or credential provided to only select users of, for example, a network service provided with system 100 (644). For example, those users which receive a health outcome determination that places them within the top 10 percentile of all users may receive a certification, which in turn enables them to receiving discounts with their healthcare provider, health insurance, or related health service activities (e.g., discount with nutrition store, athletic gym membership, life insurance, etc.). Alternatively, the designation can entitle the subset of users to receive a service, such as primary health insurance, supplemental accidental insurance, life insurance, or other membership service (whether health related or not).

In variations, the health outcome determination provides a basis for predicting a user's health, and this basis can in turn be used to determine health related services for the user (646). For example, health insurance, life insurance, and/or accidental health insurance can be provided to the user with scope and cost determined by the health outcome determination. For example, the cost of the premium or deductible to the individual user can be based on the health outcome determination (648). By way of example, an insurance service can be provided to users of system 100, and those users with better health outcome determinations can be provided discounts to their premiums or deductibles, or alternatively given greater scope of coverage as compared to counterparts users who have lesser health outcome determinations.

FIG. 6B illustrates a health service sub-system 680, according to an embodiment. A health service sub-system 680 can be implemented with or as part of, for example, system 100. In variations, the health service sub-system 680 can be provided as a separate system which interfaces with the system 100. Additionally, the health service sub-system 680 provides an example of a system on which an example of FIG. 6 can be implemented.

With reference to FIG. 6B, a health service sub-system **680** includes a system interface **682**, a customer data store **684**, and service determination logic **686**. The health service sub-system **680** can also include a service customer interface **688**, such as a web page or application page, which a service customer accesses to provide input for defining the health service offered, as well specific logic or parameters for the service determination logic **686**. The service customer input **685** can, for example, include text data definition of the service offered (e.g., terms of health or life insurance), as well a supplemental content for viewing by users of system **100**. This input can be stored in the service data store **684**.

In some variations, the service customer input **685** can further input parameters **683** and other logic (e.g., rules) for the service determination logic **686**. The parameters **683** and rules can, for example, including definition of the qualifications needed for users to (i) receive the service, (ii) receive a particular facet or tier of the service, and/or (iii) receive the service or tier according to a particular price structure. For example, the service can include tiers of benefits, or multi-tiered cost structure, and each tier can be provided to users based on qualifications, such as one or more of (i) a threshold health outcome score or set of scores, (ii) a threshold combination of health outcome score, and/or (iii) other health outcome determination.

The system interface **682** can interface with the user health database **680** in order to determine the health outcome scores **689** of a given user or user-base. In a variation, the system interface **682** can communicate with a push or trigger component on the system **100** which in turn retrieves and pushes specified health outcome scores to the system interface **682**. In some embodiments, end-users are precluded from handling health outcome data. The output of health determination logic **686** can correspond to a notification **691**, which can specify the results of the health determination logic **686**. These results can be communicated to either the user or to a provider of the health service benefit.

#### Game Play

Numerous embodiments described use of game play and logic as a mechanism to increase use response and participation. More user response and participation can have numerous benefits, including (i) increasing the size of the control group, by finding more qualified volunteers who are willing to provide real-world health information for purpose of developing health correlations to questions, (ii) more predictive correlations based on larger statistical sample, and (iii) data points from users, enabling better prediction of individual user health. Additionally, the use of game logic provides a mechanism to hide health correlative questions from public inspection, thereby precluding users from “gaming” the questions (e.g., studying) for purpose of receiving a good health score.

FIG. 7A illustrates an example method for providing a game-based environment in which user responses enable prediction of health outcomes for individual users. In describing an example method of FIG. 7A, reference may be made to elements of FIG. 1, FIG. 2 or FIG. 3 for purpose of illustrating a suitable component for performing a step or sub-step being described.

With reference to an example of FIG. 7A, a set of questions can be stored, were at least some of the questions are based on assertions that are core relative to health (**702**). For example, questions can be stored in the question library **152**, after being processed using a system such as described with an example of FIG. 2. The stored questions can include both (i) health correlative questions, which are used in determining a health outcome score or determination for the

user (**704**); and (ii) non-health correlative questions. While the latter questions may pertain to health, those questions have either not been determined to be correlative or health, or those questions have little relevance to awareness for health, and thus correlative to actual human health (**706**). As mentioned with other examples, a gaming environment can be implemented in which the questions are provided as trivia, so that users receive entertainment benefit from participating in answering questions.

Still further, as described with other examples, the health correlative questions can be process to determine a health correlative parameter (**710**). For example, question analysis subsystem **200** can be used to determine a health correlative parameter **151** for a given question. Still further, as described with other examples, the health correlative parameter can be based on persons in the control population who have knowledge (or knowledge deficit thereof) of an assertion underlying the particular question (**712**).

In order to encourage participation and development of accurate health outcome scores and determinations, a gaming environment can be established in which users are asked questions in a competitive or semi-competitive context (**720**). An example of a gaming environment is shown with environments depicted through interfaces of FIG. 8A through 8H.

The user responses to trivia questions are recorded, with those responses include both scores related to health correlative questions (**730**) and scores related to all questions (or alternatively to non-health correlative scores) (**732**). As described with an example of FIG. 6, the health correlative questions can be scored for purpose of determining health services to the user (**740**). This score may be hidden or unknown to the user, and determine independently of the overall gaming score.

Conversely, the overall gaming score can be published in a social or gaming environment, to provide the user with credentials in the community of the service provided through system **100** (**742**). For example, the user can use the latter gaming score to achieve credentials that give the user authority on message board discussions, and question and answer forums of the community platform.

In some variations, the gaming score can also provide a mechanism to provide health base recommendations to the user (**744**). For example, the user’s knowledge base can be evaluated based on topical subjects, and the user’s deficiency or strengths respect to specific topics of health can be used to infer physiological or mental information about the user.

FIG. 7B illustrates a knowledge-based recommendation engine, according to one or more embodiments. With reference to FIG. 1 and FIG. 7B, for example, the response analysis component **164** can include recommendation engine **780**. The recommendation engine **780** can use information about the user’s knowledge in order to generate recommendations **785**, which can include content that communicates to the user specific actions, lifestyle choices, or areas of growth (for knowledge or lifestyle), for purpose of growth.

In one implementation, the recommendations **785** can be based on the determinations of the user’s strength or weakness with regards to specific topics of health. The recommendation engine **780** can include processes **782** which retrieve the user’s topical scores **781**, and then correlate the topical scores with recommendation logic **790**. The recommendation logic **790** can include rules **791**, **793** for selecting recommendations for the user based on different topical scores and criteria. For example, the recommendation logic

**790** can include rules for suggesting recommendations to users for specific topics when the user's score for the topic is below a threshold. By way of example, a topic can be defined for cardiac health, and anytime a user's topical score for cardiac health is below a threshold, a set of recommendations **785** for improving the user's cardiac health can be generated and communicated to the user. Likewise, if the user's knowledge is strong in a particular topic, that can also be interpreted as interest, and the recommendation logic **790** can utilize the score to suggest recommendations that are of an advanced level. For example, if the user scores high in the topic of weight lifting, then the recommendation provided to the user can include specific techniques or recommendations based on questions that have the highest difficulty level (as determined from, for example, a calibration component **230** of FIG. 2).

In a variation, the set of recommendations **785** generated for any one topic can be associated linked with questions or sub-topics of questions. A recommendation filter **792** can filter the recommendations **785**, so as to weed out those recommendations the user likely knows based on their correctly answered questions.

Still further, the recommendation logic **790** can include combination rules, which select recommendations **785** for the user based on criterion provided by the user's topical score in two or more topics. The combination rules can identify subject matter relevancy between topics, so that the user's knowledge of one topic will benefit another or vice versa. In one implementation, when the user's topical score of one topic exceeds a threshold, and the topical score of another topic is below a threshold, then the recommendation may be provided that assumes user activity or interest in one topic to assist the user's knowledge or lifestyle with regards to the second topic. For example, the user may have scored high in the topic of weight-lifting, but scored low in nutrition or sleep. The recommendation provided to the user may identify the recommended hours for the user to sleep in order to add muscle mass.

By way of another example, if the user is strong on a subject such as weight training, but poor in nutrition, then the recommendation engine can suggest (i) that the user develop his knowledge on nutrition, (ii) identify nutritional information related to a training in order to provide recommendations. Recommendations can include, for example, with the user should eat when we training, house such nutritional intake can affect performance in retraining, recommendation for the user to confirm with a nutritionist, expected results that can be achieved through proper diet and weight training. Such an example illustrates recommendations that can be made based on the user being strong in his or her knowledge base for one topic an week in another topic. In such scenarios, the relationship between the two topics can be determined in order to generate programmatically actions and subtopics of learning which may be of interest or benefit to the user.

Similar recommendations can be determined and linked to user's topical scores based on different threshold determinations. In one implementation, if the user scores low on two topics related by subject matter, the user's recommendation may be selected on the assumption that the user suffers from health consequences related to a physiological or mental problem related to the topics.

Still further, analysis of the topical determinations can also be used to infer characteristics about the respondents, without any mathematical correlation being made to the control population. For example, an individual who scores poorly in both nutrition and exercise can be inferred to be

obese, potentially diabetic, and/or suffer from other health related issues such as depression. Based on such analysis, the recommendation engine can suggest areas of growth for the user's knowledge. The recommendation engine **780** can also provide recommended actions, such as publishing a diet to the user for weight loss, suggesting the user visits a psychiatrist (on a sound assumption that the user is depressed), suggesting the user sees a nutritionist and/or personal trainer (on the side assumption that the user is overweight), or recommend that the user have his blood sugar checked for diabetes and or high cholesterol. Such actions can follow when the user scores poorly on knowledge in topics that have synergy or relation to one another when considered for physiological or mental health.

#### Example Interfaces

FIG. **8A** through **8H** illustrate example interfaces for use with one or more embodiments described herein. Interfaces such as described with FIGS. **8A** through **8H** can be implemented using, for example, a system such as described with an example of FIG. **1**. Accordingly, reference may be made to elements of FIG. **1** for purpose of illustrating suitable components for implementing an interface as described.

In FIG. **8A**, in interface **800** provides a topical selection **804** for a user (e.g., nutrition). The interface **800** can be displayed with information from the user's profile **138**, such as their game score **802** (e.g., provided as game data **119** of the user's profile, in an example of FIG. **1**) and badges or certifications **805**.

The panel **810** of FIG. **8B** illustrates a question **812**, in the form of trivia. A set of answers **814** can be provided to the user, from which the user can make selection of in order to affect his or her score.

FIG. **8C** illustrates a panel **820** that provides feedback **825** to the user as to the correctness of the answer, as well as supplemental information regarding the correct answer and/or assertion underlying the question. In FIG. **8D**, once the user provides the answer; the user can be provided an additional panel **830**, displaying the underlying assertion **832** behind the question. Other information, such as the percentage of individuals who answer the question correctly can be displayed to the user. This feature **834** can also reflect the difficulty level of the question.

FIG. **8E** illustrates a panel **840** on which a menu of options is provided. The user can select from the menu of options. As shown, the functionality provided includes gaming (e.g., leader board) and community interaction (e.g., discussions), in a gaming and social environment such as described with an example of FIG. **1**. Additionally, the menu of options can include a health report feature **842** that can display, for example, recommendations as determined from an example of FIG. **7**.

FIG. **8F** illustrates a panel **850** that provides a gaming summary for the user, displaying the user's overall score **852**, as well as badges or honors marking **854** achievements in the number of questions the user answered etc.

FIG. **8G** illustrates a panel **860** on which a leaderboard **862** is provided. The leaderboard can be topic specific and/or categorized by user level.

FIG. **8H** illustrate the panel **870** for enabling social interaction, gaming and knowledge base forums through a system such as described with an example of FIG. **1**. Among other social interaction functions, one or more knowledge base "twins" can be identified to the user. The twins can correspond to an individual who closely shares one or more of (i) knowledge profile about health, or certain topics of health with the user, and/or (ii) similar or same health outcome values or determinations. As an addition or varia-

tion, the twin can also include similar demographic profile, such as having the same gender, age and/or race. Identify twins can be shown to each other as a mechanism for building social interaction and shared experiences, particularly as to distributing health-based knowledge, information and services.

#### Computer System

One or more embodiments described herein provide that methods, techniques and actions performed by a computing device are performed programmatically, or as a computer-implemented method. Programmatically means through the use of code, or computer-executable instructions. A programmatically performed step may or may not be automatic.

One or more embodiments described herein may be implemented using programmatic modules or components. A programmatic module or component may include a program, a subroutine, a portion of a program, or a software or a hardware component capable of performing one or more stated tasks or functions. As used herein, a module or component can exist on a hardware component independently of other modules or components. Alternatively, a module or component can be a shared element or process of other modules, programs or machines.

Furthermore, one or more embodiments described herein may be implemented through instructions that are executable by one or more processors. These instructions may be carried on a computer-readable medium. Machines shown or described with figures below provide examples of processing resources and computer-readable mediums on which instructions for implementing embodiments of the invention can be carried and/or executed. In particular, the numerous machines shown with embodiments of the invention include processor(s) and various forms of memory for holding data and instructions. Examples of computer-readable mediums include permanent memory storage devices, such as hard drives on personal computers or servers. Other examples of computer storage mediums include portable storage units, such as CD or DVD units, flash or solid state memory (such as carried on many cell phones and consumer electronic devices) and magnetic memory. Computers, terminals, network enabled devices (e.g., mobile devices such as cell phones) are all examples of machines and devices that utilize processors, memory, and instructions stored on computer-readable mediums. Additionally, embodiments may be implemented in the form of computer-programs, or a computer usable carrier medium capable of carrying such a program.

FIG. 9 is a block diagram that illustrates a computer system upon which embodiments described herein may be implemented. For example, in the context of FIG. 1, FIG. 2, FIG. 6B and FIG. 7B, a network service or system can be implemented using one or more computer systems such as described by FIG. 9. Still further, methods such as described with FIG. 4, FIG. 5, FIG. 6A and FIG. 7A can be implemented using a computer system such as described with an example of FIG. 9.

In an embodiment, computer system 900 includes processor 904, memory 906 (including non-transitory memory), storage device, and communication interface 918. Computer system 900 includes at least one processor 904 for processing information. Computer system 900 also includes a memory 906, such as a random access memory (RAM) or other dynamic storage device, for storing information and instructions to be executed by processor 904. The memory 906 also may be used for storing temporary variables or other intermediate information during execution of instructions to be executed by processor 904. Computer system 900

may also include a read only memory (ROM) or other static storage device for storing static information and instructions for processor 904. The communication interface 918 may enable the computer system 900 to communicate with one or more networks through use of the network link 920 (wireless or wireline).

In one implementation, memory 906 may store instructions for implementing functionality such as described with example systems or sub-systems of FIG. 1, FIG. 2, FIG. 6B or FIG. 7B, or implemented through example methods such as described with FIG. 4, FIG. 5, FIG. 6A or FIG. 7A. Likewise, the processor 904 may execute the instructions in providing functionality as described with example systems or sub-systems of FIG. 1, FIG. 2, FIG. 6B or FIG. 7B, or performing operations as described with example methods of FIG. 4, FIG. 5, FIG. 6A or FIG. 7A.

Embodiments described herein are related to the use of computer system 900 for implementing functionality as described herein. The memory 906, for example, can store a question library 931 (see, e.g., also question library 152 of FIG. 1), including values for health correlative parameters 933 (see e.g., also health correlative parameters 151 of FIG. 1) of the questions. The memory 906 can also store instructions 941 for determining a health score, in order to determine one or more correlative health parameters 905 for a user, in connection with the user's participation of responding to questions in an interactive community or game environment.

According to one embodiment, functionality such as described herein can be performed by computer system 900 in response to processor 904 executing one or more sequences of one or more instructions contained in the memory 906. Such instructions may be read into memory 906 from another machine-readable medium, such as through a non-transitory storage device. Execution of the sequences of instructions contained in memory 906 causes processor 904 to perform the process steps described herein. In alternative embodiments, hard-wired circuitry may be used in place of or in combination with software instructions to implement embodiments described herein. Thus, embodiments described are not limited to any specific combination of hardware circuitry and software.

Although illustrative embodiments have been described in detail herein with reference to the accompanying drawings, variations to specific embodiments and details are encompassed by this disclosure. It is intended that the scope of embodiments described herein be defined by claims and their equivalents. Furthermore, it is contemplated that a particular feature described, either individually or as part of an embodiment, can be combined with other individually described features, or parts of other embodiments. Thus, absence of describing combinations should not preclude the inventor(s) from claiming rights to such combinations.

What is claimed is:

1. A network computing system implementing a health service comprising:

a communication interface connecting the network computing system, over one or more wireless networks, with a health service application executing on computing devices of users of the health service;

a database storing a collection of health trivia questions pertaining to human health, wherein each respective health trivia question in the collection of health questions comprises (i) a correlative health value based on answers to the respective health question from individuals in a control group of which a health outcome is known, and (ii) a difficulty level, and wherein the

23

collection of health trivia questions are configured to test general health knowledge of the users of the health service and not query user-specific health information of the users;

one or more processors; and

a memory storing instructions that, when executed by the one or more processors, cause the network computing system to:

detect, over the one or more wireless networks, initiation of a trivia session from a computing device of a user of the health service, the initiation of the trivia session corresponding to the health service application being executed on the computing device of the user;

in response to the initiation of the trivia session, obtain profile data of the user to select a plurality of health trivia questions from the collection of health trivia questions in the database, and sequentially provide, over the one or more wireless networks, the plurality health trivia questions for display on the computing device of the user via the executing health service application;

receive, sequentially over the one or more wireless networks, a corresponding response to each health trivia question of the plurality of health trivia questions from the health service application executing on the computing device of the user;

determine, for each answered health trivia question of the plurality of health trivia questions, the difficulty level for the answered health trivia question and a correctness of the corresponding response to the answered health trivia question, the correctness indicating whether the user responded to the answered health trivia question correctly or incorrectly;

based on the difficulty level of each answered health trivia question and the correctness of the corresponding response to each answered health trivia question, generate a health knowledge profile for the user, the health knowledge profile indicating a health knowledge level of the user as compared to other users of the health service;

based on (i) the health knowledge profile of the user and (ii) the correlative health value of each answered health trivia question of the plurality of health trivia questions, determine a predicted health outcome of the user, the predicted health outcome corresponding to at least one of a predicted health care cost, a predicted number of medical center visits, a predicted number of prescriptions, a predicted number of sick days, or a propensity for disease for the user over a given time frame;

based on the predicted health outcome of the user, determine a health service benefit for the user, the health service benefit corresponding to at least one of an insurance premium, an insurance deductible, a scope of insurance coverage, an insurance discount, or a health service plan; and

generate, over the one or more wireless networks, a service customer interface via the health service application executing on the computing device of the user, the service customer interface providing the user with the health service benefit determined based on the predicted health outcome of the user.

2. The network computing system of claim 1, wherein the executed instructions cause the network computing system to provide a response score for each corresponding response

24

to each answered health trivia question, the response score being displayed on the computing device of the user after each corresponding response.

3. The network computing system of claim 1, wherein the executed instructions further cause the network computing system to:

provide, over the one or more wireless networks, a set of health recommendations for display on the computing device of the user.

4. The network computing system of claim 3, wherein the set of health recommendations are included in a selectable health report feature displayed on the computing device of the user.

5. The network computing system of claim 3, wherein the executed instructions cause the network computing system to provide the set of health recommendations based on the health knowledge level of the user being below a threshold.

6. The network computing system of claim 1, wherein the executed instructions further cause the network computing system to:

determine, based on the health knowledge profile of the user, whether the health knowledge level of the user exceeds a threshold; and

when the health knowledge level of the user exceeds the threshold, generate, via a user interface element on the computing device of the user, a certification for the user, the certification enabling the user to receive the health service benefit.

7. The network computing system of claim 1, wherein the predicted health outcome corresponds to mental health of the user.

8. The network computing system of claim 1, wherein the predicted health outcome corresponds to physiological health of the user.

9. The network computing system of claim 1, wherein the plurality of health trivia questions corresponds to a specified health topic, and wherein the predicted health outcome of the user also corresponds to the specified health topic.

10. The network computing system of claim 9, wherein the specified health topic comprises one of nutrition, exercise, or a specified medical condition.

11. The network computing system of claim 1, wherein the executed instructions cause the network computing system to determine that the user has a medical condition based on the corresponding responses to the plurality of health trivia questions.

12. A non-transitory computer-readable medium storing instructions that, when executed by one or more processors of a network computing system, cause the network computing system to:

communicate, over one or more wireless networks, with a health service application executing on computing devices of users of a health service;

detect, over one or more wireless networks, initiation of a trivia session from a computing device of a user of the health service, the initiation of the trivia session corresponding to the health service application being executed on the computing device of the user;

store, in a database, a collection of health trivia questions pertaining to human health, wherein each respective health trivia question in the collection of health questions comprises (i) a correlative health value based on answers to the respective health question from individuals in a control group of which a health outcome is known, and (ii) a difficulty level, and wherein the collection of health trivia questions are configured to



test general health knowledge of the users of the health service and not query user-specific health information of the users;

in response to the initiation of the trivia session, obtain profile data of the user to select a plurality of health trivia questions from the collection of health trivia questions in the database, and sequentially provide, over the one or more wireless networks, the plurality health trivia questions for display on the computing device of the user via the executing health service application;

receive, sequentially over the one or more wireless networks, a corresponding response to each health trivia question of the plurality of trivia questions from the health service application executing on the computing device of the user;

determine, for each answered health trivia question of the plurality of trivia questions, the difficulty level for the answered health trivia question and a correctness of the corresponding response to the answered health trivia question, the correctness indicating whether the user has responded to the answered health trivia question correctly or incorrectly;

based on the difficulty level of each answered health trivia question and the correctness of the corresponding response to each answered health trivia question, generate a health knowledge profile for the user, the health knowledge profile indicating a health knowledge level of the user as compared to other users of the health service;

based on (i) the health knowledge profile of the user and (ii) the correlative health value of each answered health trivia question of the plurality of health trivia questions, determine a predicted health outcome of the user, the predicted health outcome corresponding to at least one of a predicted health care cost, a predicted number medical center visits, a predicted number of prescriptions, a predicted number of sick days, or a propensity for disease for the user over a given time frame;

based on the predicted health outcome of the user, determine a health service benefit for the user, the health service benefit corresponding to at least one of an insurance premium, an insurance deductible, a scope of insurance coverage, an insurance discount, or a health service plan; and

generate, over the one or more wireless networks, a service customer interface via the health service application executing on the computing device of the user, the service customer interface providing the user with the health service benefit determined based on the predicted health outcome of the user.

**13.** The non-transitory computer-readable medium of claim **12**, wherein the executed instructions cause the network computing system to provide a response score for each corresponding response to each answered health trivia question, the response score being displayed on the computing device of the user after each corresponding response.

**14.** The non-transitory computer-readable medium of claim **12**, wherein the executed instructions further cause the network computing system to:

provide, over the one or more wireless networks, a set of health recommendations for display on the computing device of the user.

**15.** The non-transitory computer-readable medium of claim **14**, wherein the set of health recommendations are included in a selectable health report feature displayed on the computing device of the user.

**16.** The non-transitory computer-readable medium of claim **14**, wherein the executed instructions cause the network computing system to provide the set of health recommendations based on the health knowledge level of the user being below a threshold.

**17.** The non-transitory computer-readable medium of claim **12**, wherein the executed instructions further cause the network computing system to:

determine, based on the health knowledge profile of the user, whether the health knowledge level of the user exceeds a threshold; and

when the health knowledge level of the user exceeds the threshold, generate, via a user interface element on the computing device of the user, a certification for the user, the certification enabling the user to receive the health service benefit.

**18.** The non-transitory computer-readable medium of claim **12**, wherein the predicted health outcome corresponds to mental health of the user.

**19.** The non-transitory computer-readable medium of claim **12**, wherein the predicted health outcome corresponds to physiological health of the user.

**20.** A computer-implemented method of implementing a health service, the method being performed by one or more processors and comprising:

communicating, over one or more wireless networks, with a health service application executing on computing devices of users of the health service;

storing, in a database, a collection of health trivia questions pertaining to human health, wherein each respective health trivia question in the collection of health questions comprises (i) a correlative health value based on answers to the respective health question from individuals in a control group of which a health outcome is known, and (ii) a difficulty level, and wherein the collection of health trivia questions are configured to test general health knowledge of the users of the health service and not query user-specific health information of the users;

detecting, over one or more wireless networks, initiation of a trivia session from a computing device of a user of the health service, the initiation of the trivia session corresponding to the health service application being executed on the computing device of the user;

in response to the initiation of the trivia session, obtaining profile data of the user to select a plurality of health trivia questions from the collection of health trivia questions in the database, and sequentially providing, over the one or more wireless networks, the plurality health trivia questions for display on the computing device of the user via the executing health service application;

receiving, sequentially over the one or more wireless networks, a corresponding response to each health trivia question of the plurality of health trivia questions from the health service application executing on the computing device of the user;

determining, for each answered health trivia question of the plurality of health trivia questions, the difficulty level for the answered health trivia question and a correctness of the corresponding response to the answered health trivia question, the correctness indicating whether the user responded to the answered health trivia question correctly or incorrectly;

based on the difficulty level of each answered health trivia question and the correctness of the corresponding response to each answered health trivia question, gen-

erating a health knowledge profile for the user, the health knowledge profile indicating a health knowledge level of the user as compared to other users of the health service;

based on (i) the health knowledge profile of the user and 5  
(ii) the correlative health value of each answered health trivia question of the plurality of health trivia questions, determining a predicted health outcome of the user, the predicted health outcome corresponding to at least one of a predicted health care cost, a predicted number 10  
medical center visits, a predicted number of prescriptions, a predicted number of sick days, or a propensity for disease for the user over a given time frame;

based on the predicted health outcome of the user, determining a health service benefit for the user, the health 15  
service benefit corresponding to at least one of an insurance premium, an insurance deductible, a scope of insurance coverage, an insurance discount, or a health service plan; and

generating, over the one or more wireless networks, a 20  
service customer interface via the health service application executing on the computing device of the user, the service customer interface providing the user with the health service benefit determined based on the predicted health outcome of the user. 25

\* \* \* \* \*